



**Moving Head**  
**GTD-1500 N Profile**  
**User's Manual**

**Guangzhou GTD Culture & Technology Group Co.,Ltd**

Tel: +86-20-61808296

Fax: +86-20-61812282

<http://www.gtd-lighting.com>

©2018 GTD all rights reserved. Information, specifications, diagrams, images, and instructions herein are subject to change without notice. GTD logo and identifying product names and numbers herein are trademarks of GTD. Copyright protection claimed includes all forms and matters of copyrightable materials and information now allowed by statutory or judicial law or hereinafter granted. Product names used in this document may be trademarks or registered trademarks of their respective companies and are hereby acknowledged. All non-GTD brands and product names are trademarks or registered trademarks of their respective companies.







GTD and all affiliated companies hereby disclaim any and all liabilities for property, equipment, building, and electrical damages, injuries to any persons, and direct or indirect economic loss associated with the use or reliance of any information contained within this document, and/or as a result of the improper, unsafe, insufficient and negligent assembly, installation, rigging, and operation of this product.



## Contents

<b>Safety instructions</b> .....	<b>3</b>
<b>General guidelines</b> .....	<b>4</b>
<b>Packing and shipping</b> .....	<b>6</b>
Protection lock.....	6
Unpacking .....	6
Packing after use.....	5
<b>Accessories</b> .....	<b>7</b>
<b>Product introduction</b> .....	<b>7</b>
<b>Installation</b> .....	<b>7</b>
Clamps installation .....	7
Device installation .....	7
<b>Lamp fitting and adjustment</b> .....	<b>8</b>
<b>Power / Control connection</b> .....	<b>9</b>
Power connection .....	9
Control connection .....	9
Testing .....	9
<b>Control panel</b> .....	<b>11</b>
<b>Gobos and colors</b> .....	<b>12</b>
Gobo specification .....	12
Gobos.....	12
Colors .....	13
Cutting effects .....	13
<b>Menu structure</b> .....	<b>14</b>
<b>DMX protocol</b> .....	<b>15</b>
<b>Technical specification</b> .....	<b>26</b>
<b>Cleaning and maintenance</b> .....	<b>30</b>
<b>Troubleshooting</b> .....	<b>30</b>
<b>System wiring diagram</b> .....	<b>32</b>
<b>Spare parts list</b> .....	<b>34</b>
<b>Appendix 1</b> .....	<b>34</b>

## Safety instructions

	<p><b>WARNING!</b></p> <p>Before using the fixture, read the latest version of the product user manual, paying particular attention to the safety instructions. Please check <a href="http://www.gtd-lighting.com">www.gtd-lighting.com</a> for the latest revision/update of the user manual. The manufacture of this fixture, are not responsible for damages, resulting from misuse of this fixture, due to the disregard of the information printed in this user manual.</p>
	<p><b>DANGER!</b></p> <p>Hazardous voltage. Risk of lethal or severe electric shock.</p>
	<p><b>WARNING!</b></p> <p>Burn hazard. Hot surface. Do not touch.</p>
	<p><b>WARNING!</b></p> <p>Fire hazard.</p>
	<p><b>INDOORS USE ONLY!</b></p> <p>Do not expose fixture for rain and moisture.</p>
	<p>It's essential that the fixture is properly grounded. Only qualified personnel should perform electrical connections.</p>
	<p><b>WARNING!</b></p> <p>Wear protective eyewear. Never look directly into the light source.</p>

- Only qualified and certified personnel should perform installation of this fixture and only the original rigging parts (brackets) included with this fixture should be used for installation.
- Before applying power to the fixture, check that the source voltage matches the fixture's requirement. Every fixture must be earthed (grounded) and installed in accordance with local electricity regulations. Do not connect it to a dimmer system.
- Never look directly into the light source of this fixture to prevent risk of injury to your retina, which may induce blindness.

## General guidelines

- Never open this fixture while in use.
- The fixture should be kept clean. **DO NOT** operate the fixture in extreme heat or dusty environments. Avoid contact with chemical liquid.
- This fixture is a professional light effect designed for **INDOOR / DRY LOCATIONS ONLY** on stage, in nightclubs, theatres, etc.
- **Minimum** distance to lighted objects must be **9.84feet (3m)**.
- **Maximum** temp of the external surface **248°F (120°C)**.
- **Maximum** ambient temperature **113°F (45°C)**.
- **Minimum** distance of inflammable materials from the surface **1.6 feet (0.5m)**.
- Lamp should be changed if damaged or distorted in shape due to extreme heat.
- Cover, prism or LCD Menu Function Display with visible damages such as cracks or scratches must be replaced to ensure performance of the fixture.
- Disconnect the fixture from power before changing any parts or accessories.
- Make sure that the installation area can hold a minimum point load of 10 times the weight of all installed fixtures, clamps, cables, auxiliary equipment, etc. Check that the cover, clamps and locks are undamaged. Certified safety cables must always be used when installing the fixture.
- The fixture is only intended for installation, operation and maintenance by qualified professional. Instructions stated in the manual must be complied.
- The fixture must be kept in a well-ventilated place at least 50 cm away from any wall surface. Check if the fans or ventilation openings are unblocked.
- This fixture uses discharge lamp. To avoid reducing the lamp's life, wait at least 15 minutes after powering off to allow the unit to cool down before handling.
- Broken or damaged cables can only be fixed or changed by certified technicians, certified local distributors or the manufacturer to ensure operational safety.
- Do not stick filters or other materials onto the lens. Do not modify the fixture or install other than GTD manufactured parts.
- For questions regarding safety operation, please contact our technical personnel or call the service hotline +8620 61808296.

## Packing and shipping

### Protection lock

Pan and tilt locks are equipped to ensure safe transportation.

PAN: 4 lock positions are located evenly on the Pan.

TILT: 5 lock positions are located on left and right side of the Tilt with the third one in the center.

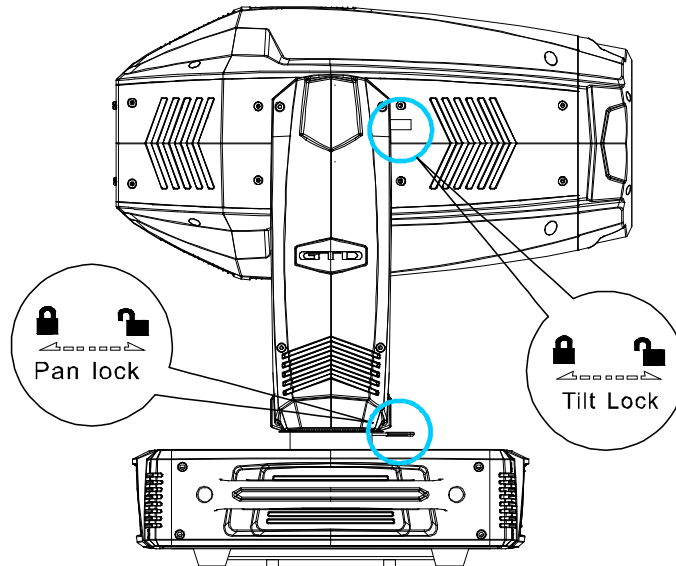

### Unpacking

#### ⚠️Notes

All products are quality controlled and checked for any faults before they are dispatched to customers. If the fixture is damaged during delivery, the customer must notify the shipper and manufacturer to file a damage insurance claim. Photographic evidence of the damage must be provided.

#### Flight-Case

Open the cover of the flight-case and remove the plastic packing bags. Hold the handles of the fixture firmly and take it out carefully.

#### Cardboard box

Open the box and take out the whole set of packaging foam which contains both the fixture and its accessories. Remove the foam from the top, put away the accessories, and then take out the fixture wrapped in the plastic bag.

#### ⚠️Notes

Check if the pan and tilt are unlocked before connecting the fixture to power.

### Packing after use

1. Switch off the fixture and wait for at least 5 minutes before disconnecting it from AC power. Cool down the fixture for at least 15 minutes before packing.
2. Lock pan and tilt.
3. Flight case: Wrap the fixture in plastic bags. Hold it by the handles, and then carefully place it inside the flight case along with all the accessories. Close the cover. Only 2 layers are allowed when piling up the flight cases. Do not upside down.  
Cardboard box: Wrap the fixture in plastic bags. Put it in the packaging foam along with all the accessories. Place the other set of packaging foam on top then carefully put it inside the cardboard box.

**Accessories**

Item	Qty	Unit	Notes
User Manual	1	pc	-
Clamps	2	set	G-clamp with 1/4-turn fasteners, for Ø42-52mm, Max. 200 kg
Power cable	1	pc	

**⚠Notes**

Accessories are subject to change without any prior written notice.

**Product introduction**

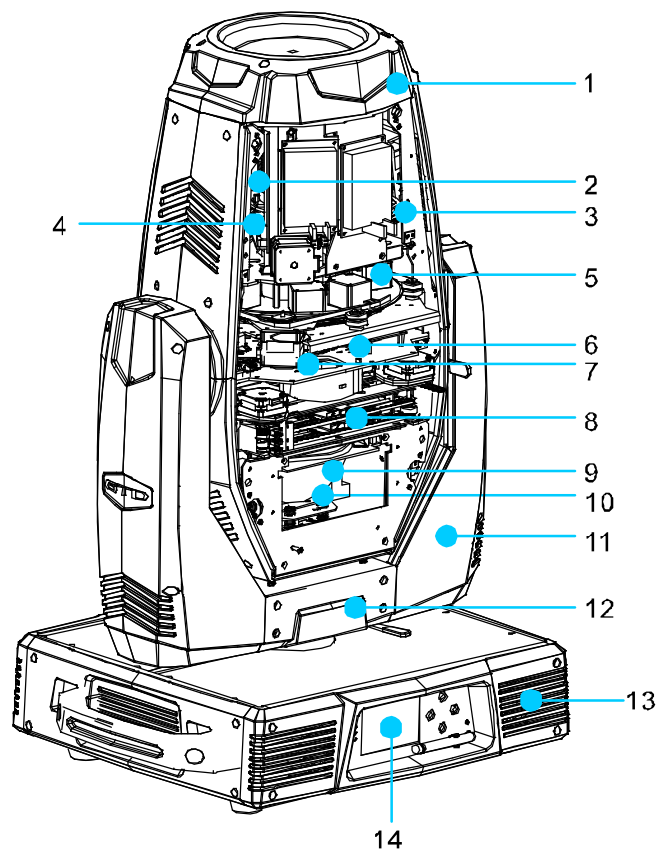

- |                        |                        |                       |
|------------------------|------------------------|-----------------------|
| 1 Head                 | 2 Zoom                 | 3 Prism               |
| 4 Focus                | 5 Framing blade system | 6 Gobo wheel assembly |
| 7 Color wheel assembly | 8 CMY                  | 9 Reflector           |
| 10 Lamp source         | 11 Tilt                | 12 Pan                |
| 13 Base                | 14 Display             |                       |



## Installation

### Clamps installation

The fixture can be placed on the stage or mounted on the truss facing any direction. Attach the clamps to the mounting position on the base of the fixture.

#### Warning

Use two clamps when mounting the fixture. Turn the screws attached to each clamp a 1/4 turn clockwise to lock. Always remember to use the safety cable which goes through the mounting hole on the base. Do not attach the safety cable on the handle.

### Device installation

1. Make sure there is no damage on the clamps or safety cables before installation.
2. The clamp is mounted on the chassis of the fixture. Horizontally insert the clamp into the mounting holes of the chassis. Fasten the clamp tightly by a 1/4 turn clockwise. Fix another clamp in the same way.
3. Check if pan and tilt are unlocked before connecting the unit to AC power.

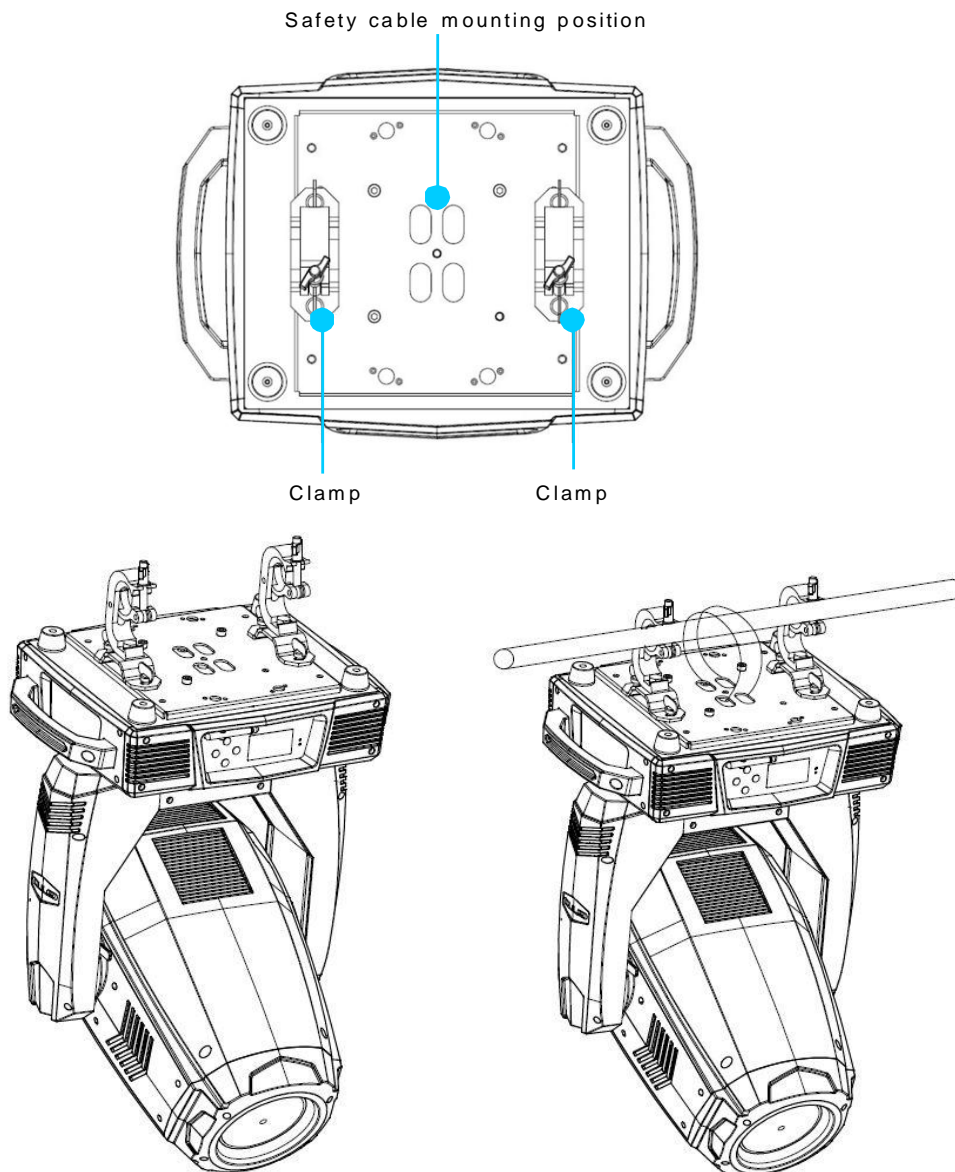

## Lamp fitting and adjustment

1. Disconnect the power, cool down the fixture, and set the Tilt lock-catch on the arm in a horizontal position.
2. Use a flathead screwdriver to rotate 1/4 circle counter-clockwise to unscrew the four quick bolts on the lamp's back-cover.
3. Pull the back cover out gently in parallel direction by hands, and pull it in full place to let it drop down naturally.
4. Let the dot on the sphere of the lamp face to the back and the sphere face to the front, put the lamp horizontally into the slot on the lamp-holder and make sure that the lamp's metal handle already be in alignment with the bayonet edge of the holder. Then press the metal legs at the ends of the lamp gently down to the right position, and make sure the lamp has been fixed well to the position.
5. And then push the back-holder with the fixed lamp gently into the reflector, meanwhile observe the outlet of the reflector when pushing, and use a flathead screwdriver to fasten the back cover by rotating the quick bolt 1/4 circle clockwise.

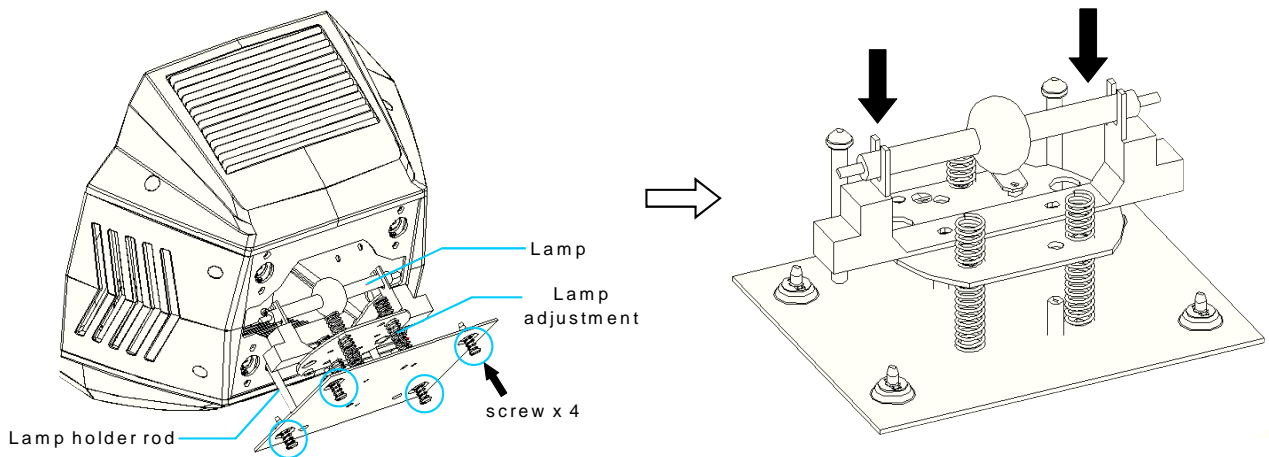

### ⚠ Notes

The fixture is equipped with Metal Halide 1500W short arc discharge lamp, which is featured with high efficiency and short-arc characteristic, such as a stable 6000K color-temperature and average lifespan of 750 hrs.

The lamp is equipped with special designed bayonets at both ends. The K575B double ended lamp holder must be applied to ensure proper installation.

### ⚠ Warning

Fitting another type of lamp will cause potential damage to the fixture. Change the lamp before it reaches its lifespan. Read the guidelines in the package carefully when fixing the lamp.

To avoid any impact on the beam, do not touch the bulb with your bare hands. The lamp must be kept clean with the use of the clean paper contained in its package.

## Lamp adjustment

1. Turn on the power to reset the fixture, cast a beam of white light spot via the menu or the console.
2. Adjust the position of the lamp with hex wrench to screws of A, B and C on the lamp's back cover corresponding to the left offset, the right offset and offset back and forth, pay attention to the white light spot while adjusting the screws until the uniformity of the spot comes to the best effect.

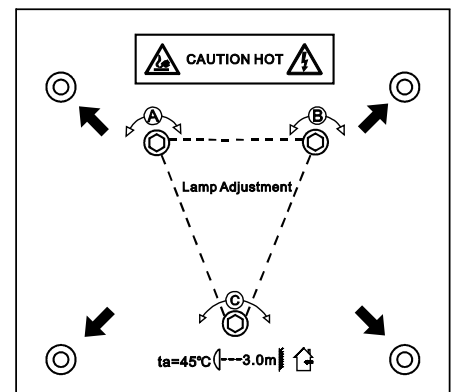

## Power/ Control connection

### Power connection

Connection method:

- L (Live) Brown wire
- E (Earth) Yellow / Green bi-color wire
- N (Neutral) Blue wire
- The voltage and frequency of the power source must be in compliance with the ones marked on the fixture. It is strongly recommended that each fixture are to be connected to the power source separately so that they can be switched on / off individually.

### Control connection

The fixture has 5-pin and 3-pin XLR connectors for DMX data input and output as shown below. Connection between the console and fixture, and between fixtures must be made with 2 core screened DMX signal cable. Maximum connecting distance of signal cable is 150 meters. Additional DMX512 signal-amplifier is recommended for longer distance.

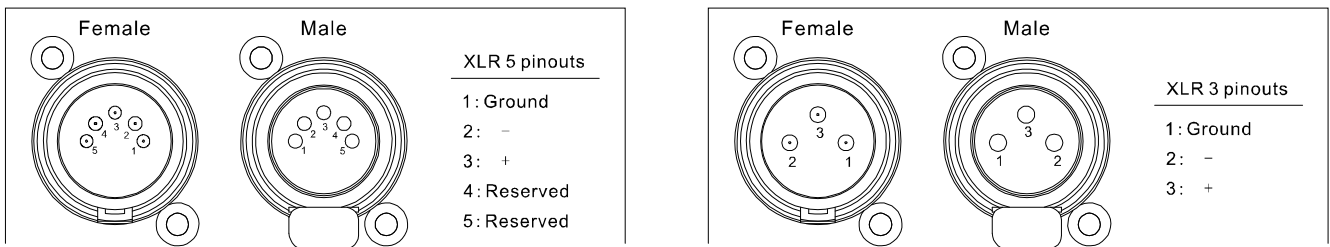

Connect the Console’s DMX OUTPUT to the first fixture’s DMX INPUT, then the first fixture’s DMX OUTPUT to the second fixture’s DMX INPUT and so on. It is recommended not to connect more than 32 units on a single DMX universe. On the last fixture’s output connect a DMX terminator. (The terminator is a XLR connector with a ¼ W and 120Ω resistor between the pin 2 and pin 3) as shown below:

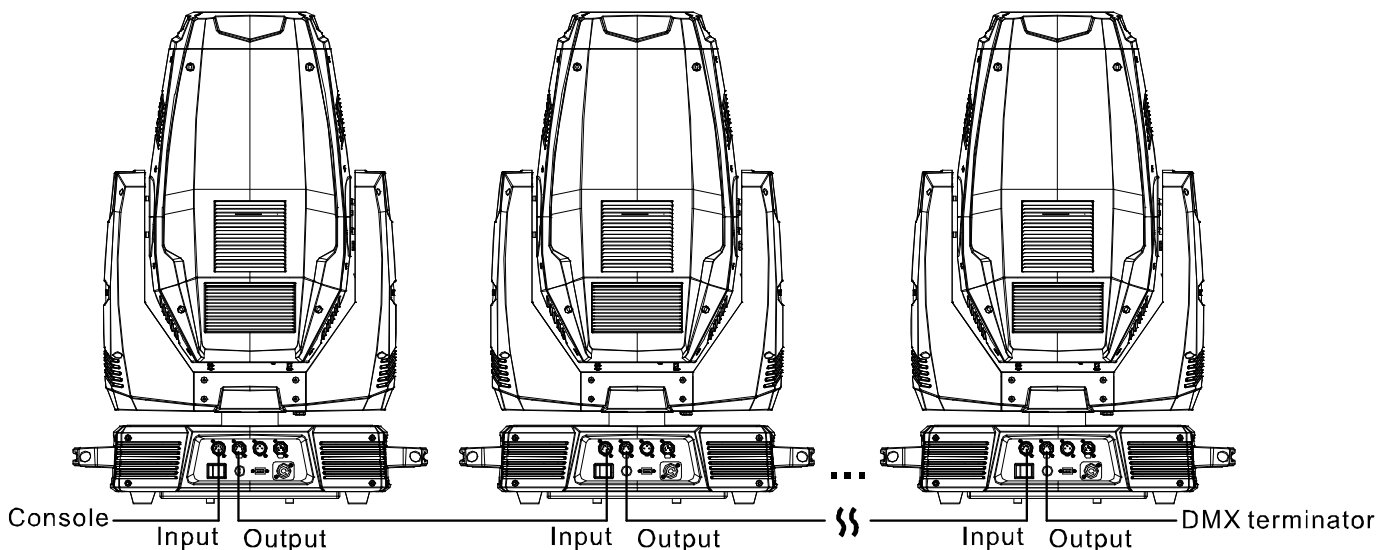

### Testing

Connect the fixture to AC power. Check if the lamp is on and the fixture is independently controllable before putting into operation.

## Control panel

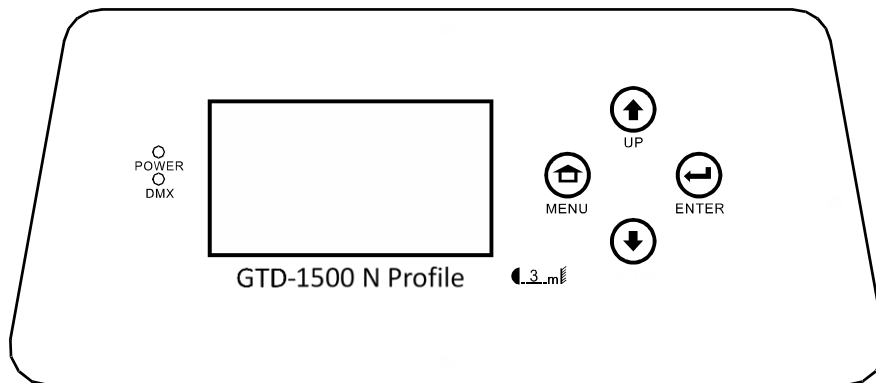

- The control panel features touch-sensitive buttons and LCD digital display for quick and easy setup of address code and functions menu.
- Press UP or DOWN to view or select the function menu.
- Press ENTER to choose a function and enter into corresponding sub menu. Each menu represents a specific function of the fixture.
- Press ENTER to select the specific function and save the changes or enter into the submenu, then press UP or DOWN to change the value of the selected function (increase or decrease).
- Press MENU to return to the previous menu or exit.
- LED indicators:
  - Power on: RED power LED indicator on
  - Signal on: Green DMX indicator on
  - No Signal: Green DMX indicator off

## Gobos and colors

### Gobo specification

All patterns are made onto the metal or glass gobos, and can be customized according to user's requirement. The customized size is as below:

Gobo material	Outer dimension	Effective dimension	Thickness
Glass gobo	ϕ 33mm	ϕ 27mm	ϕ 1mm
Metal gobo	ϕ 33mm	ϕ 27mm	ϕ 0.5mm

#### Notes

Glass Gobo is made of high temperature resistant glass. Metal Gobo is made of high temperature resistant aluminum alloy in laser cutting.

### Gobos

- One rotating gobo wheel: 5 interchangeable gobos + open, indexing, CW/CCW rotation, variable speed
- One fixed gobo wheel: 7 gobos + open, CW/CCW rotation, variable speed

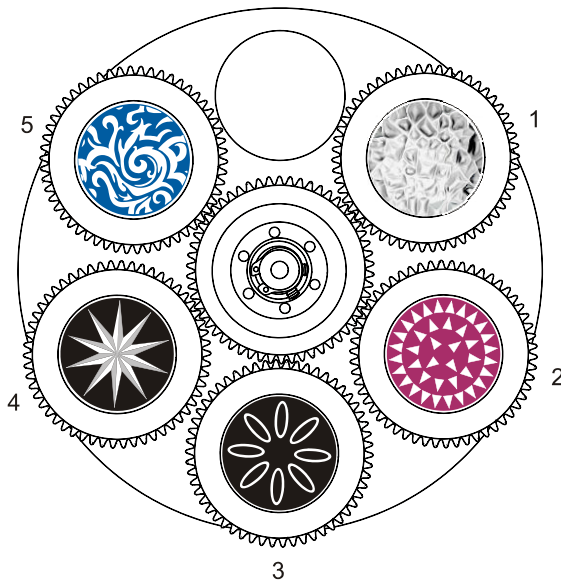

Rotating gobo wheel

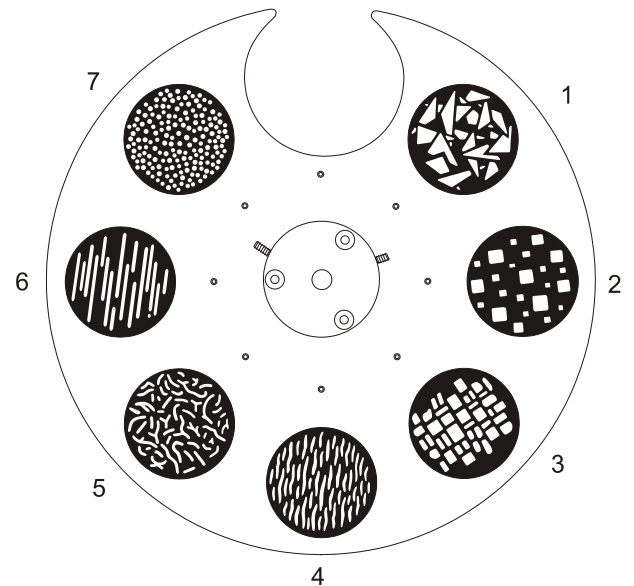

Fixed gobo wheel

**Colors**

- One color wheel: 7 colors + open, split color, CW/CCW rotation, variable speed

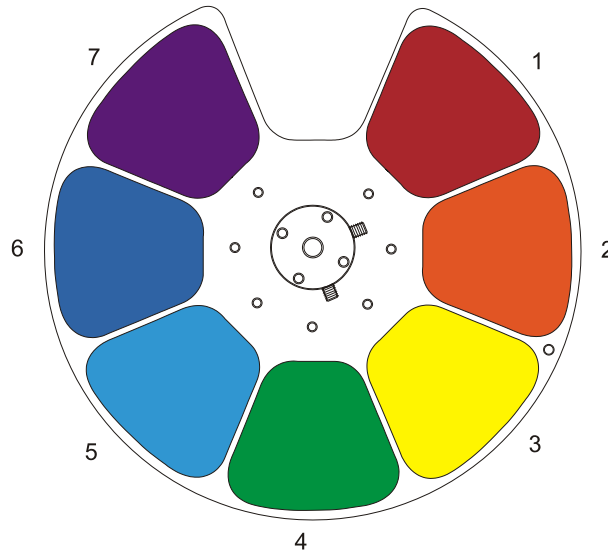

- 1: red
- 2: orange
- 3: yellow
- 4: green
- 5: light blue
- 6: dark blue
- 7: purple

**Cutting effects**

Some cutting effects

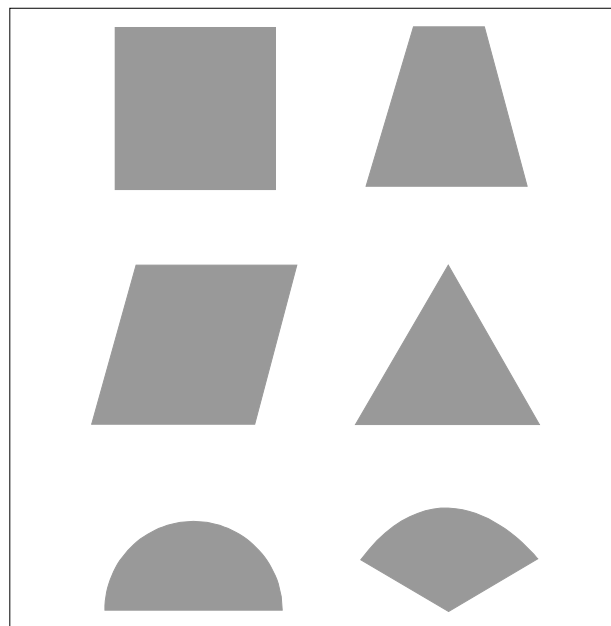

**Menu structure**

<b>1500 N Profile – Menu Structure</b>	
Revision: A	Valid from firmware version: 3.0

Level 1	Level 2	Level 3	Level 4	Info
Run setting	Address Setting Value Display Slave Address Auto-Program Music Program	Address: 001~ XXX Pan ....., All, Off Slave 1,2,3 Master /Slave Master/ Slave		Setting the DMX address Display the channel value Choose the slave address Run auto program in master or slave Run music program in master or slave
Device Info	Time Info	Since power on Total Time Last Time Lamp On Time Lamp Off Time Last Time Code Clear Last Time Lamp Time Code Clear Lamp Time	XXXXXX Hour XXXXXX Hour XXXXXX Hour XXXXXX Hour XXXXXX Minute Password: XXX(88) Yes/No Password: XXX(111) Yes/No	Since power on time Product total run time Last product run time Lamp on time Lamp close time Clear last time password Clear last time Clear lamp time password Clear lamp time
	Temperature	Body Temperature	XXX 'C/'F	Body temperature
	Software Version	X.X		The software version
Lamp Control	Lamp On/Off Power On Lamp On Console Lamp On Console Lamp Off Lamp On Temp. Lamp Off Temp.	On/Off Enable/Disable Enable/Disable Enable/Disable 20~79, 45'C /68~174 , 113'F 80~139, 130'C/176~282,266'F		Open lamp Power on open lamp Console open lamp Console close lamp Open lamp below temperature Close lamp above temperature
System Setting	Status Setting	Console Set Addr No Signal Status Pan Reverse Tilt Reverse Pan Scan Degree Scan Feedback Scan Speed Mic. Sensitivity Standby Time	Enable/Disable Off/Hold/Auto/Music Enable/Disable Enable/Disable 630/540 Enable/Disable Quick/Middle/Low/Slow 0~99% Disable/1~20~99 Min	Address can be changed by console The status while no signal Pan Reverse Tilt Reverse Pan Scan Degree Scan Feedback Change the scan speed Microphone sensitivity Standby time
	Fan Speed	Smart Control High Speed Low Speed		Auto fans speed Fans high speed Fans low speed
	Display Setting	Backlight Time Key Lock Language	1~80 Min/Disable Enable/Disable Chinese/English	Backlight off time Press <menu> 3s to unlock Change the language

**Notes**

Settings highlighted in light grey are default values.

Level 1	Level 2	Level 3	Level 4	Info
System Setting	Temperature Unit	Celsius Fahrenheit		Temperature unit
	Value Default	Pan.....	Pan =XXX	The default value
	Wireless Dev	Wireless Off Wireless On Wireless Trans. Wireless Reset		Wireless off Wireless on Wireless transfer DMX data to another Wireless reset
	Restore Default	Restore/Cancel		Restore to default value
Reset	System Reset Scan Reset Color Reset Gobo Reset Strobe Reset Blade Reset Others Reset			System reset Pan an tilt motor reset All color motor reset All gobo motor reset All strobe motor reset All blade motor reset All other motor reset
Channel Adjust	Test Mode	Pan .....		Every channel test
	Manual Mode	Pan :	Pan = XXX :	Manual control
	Adjust Mode	Input Password Pan :	Password = XXX(99) Pan = XXX :	The password of adjust mode Fixed all begin position
Channel Setting	Channel Mode	Standard Mode Simplified Mode Extended Mode Custom Mode 1 Custom Mode 2 Custom Mode 3		Standard channel mode Simplified channel mode Extended channel mode Custom channel mode 1 Custom channel mode 2 Custom channel mode 3
	Set Custom Mode 1 Set Custom Mode 2 Set Custom Mode 3	Max Channel Pan :	Channel = XX Pan = CH01 :	Change the channel order
Program Edit	Select Prog.	Program Unit 1 Program Unit 2 Program Unit 3	Program 1 ~10 Program 1 ~ 10 Program 1 ~ 10	Choose build-in program for slave 1 Choose build-in program for slave 2 Choose build-in program for slave 3
	Program Edit	Auto-Program1 : Auto-Program10	Run Step 1 = Scene xxx Step 8 = Scene xxx	Choose the scene for program 1 : Choose the scene for program 10
	Scene Edit	Scene Edit: 001-250	Pan, .....Pan = xxx Scene Time = xxx Input By Console	Edit the channel DMX Edit the scene time Get scene DMX form console
	Record Scene	Scene XX->XX		Record scene form console

**Notes**

Settings highlighted in light grey are default values.



**DMX protocol**

<b>1500 N profile - DMX Protocol</b>	
Revision: A	Valid from firmware version: 3.0

**DMX protocol - Standard [35 channels]**

Standard (35ch)	Name	DMX value		DMX percentage		Function	Default DMX Value
1	Strobe/Shutter	0	31	0.0%	12.2%	Closed	0(0%)
		32	63	12.5%	24.7%	Open	
		64	127	25.1%	49.8%	Synchronous strobe from slow to fast	
		128	159	50.2%	62.4%	Open	
		160	223	62.7%	87.5%	Random strobe from slow to fast	
		224	255	87.8%	100.0%	Open	
2	Intensity	0	255	0.0%	100.0%	No light → Full light	0(0%)
		0	255	0.0%	100.0%	Intensity fade, fine (LSB)	
3	Cyan	0	255	0.0%	100.0%	White → Full cyan	0(0%)
		0	255	0.0%	100.0%	Cyan fade, fine (LSB)	
4	Magenta	0	255	0.0%	100.0%	White → Full magenta	0(0%)
		0	255	0.0%	100.0%	Magenta fade, fine (LSB)	
5	Yellow	0	255	0.0%	100.0%	White → Full yellow	0(0%)
		0	255	0.0%	100.0%	Yellow fade, fine (LSB)	
6	CMY color macro	0	15	0.0%	5.9%	CMY color macro off	0(0%)
		16	135	6.3%	52.9%	CMY synchronous color from slow to fast	
		136	255	53.3%	100.0%	CMY random color from slow to fast	
7	CTO	0	255	0.0%	100.0%	Warm → Cold	0(0%)
		0	255	0.0%	100.0%	CTO fade, fine (LSB)	
8	Color wheel	0	15	0.0%	5.9%	Open	0(0%)
		16	31	6.3%	12.2%	Color 1	
		32	47	12.5%	18.4%	Color 2	
		48	63	18.8%	24.7%	Color 3	
		64	79	25.1%	31.0%	Color 4	
		80	95	31.4%	37.3%	Color 5	
		96	111	37.6%	43.5%	Color 6	
		112	127	43.9%	49.8%	Color 7	
		128	187	50.2%	73.3%	Color continous rotation CW from slow to fast	
		188	195	73.7%	76.5%	Stop	
		196	255	76.9%	100.0%	Color continous rotation CCW from slow to fast	
9	Gobo wheel (static)	0	15	0.0%	5.9%	Open	0(0%)
		16	23	6.3%	9.0%	Gobo 1	

Standard (35ch)	Name	DMX value		DMX percentage		Function	Default DMX Value
		24	31	9.4%	12.2%	Gobo 2	
		32	39	12.5%	15.3%	Gobo 3	
		40	47	15.7%	18.4%	Gobo 4	
		48	55	18.8%	21.6%	Gobo 5	
		56	63	22.0%	24.7%	Gobo 6	
		64	71	25.1%	27.8%	Gobo 7	
		72	79	28.2%	31.0%	Gobo 1 shake	
		80	87	31.4%	34.1%	Gobo 2 shake	
		88	95	34.5%	37.3%	Gobo 3 shake	
		96	103	37.6%	40.4%	Gobo 4 shake	
		104	111	40.8%	43.5%	Gobo 5 shake	
		112	119	43.9%	46.7%	Gobo 6 shake	
		120	127	47.1%	49.8%	Gobo 7 shake	
		128	187	50.2%	73.3%	Gobo wheel continous rotation CW from slow to fast	
		188	195	73.7%	76.5%	Stop	
		196	255	76.9%	100.0%	Gobo wheel continous rotation CCW from slow to fast	
10	Rotating gobo wheel 1	0	27	0.0%	10.6%	Open gobo	0(0%)
		28	37	11.0%	14.5%	Gobo 1	
		38	47	14.9%	18.4%	Gobo 2	
		48	57	18.8%	22.4%	Gobo 3	
		58	67	22.7%	26.3%	Gobo 4	
		68	77	26.7%	30.2%	Gobo 5	
		78	87	30.6%	34.1%	Gobo 1 shake	
		88	97	34.5%	38.0%	Gobo 2 shake	
		98	107	38.4%	42.0%	Gobo 3 shake	
		108	117	42.4%	45.9%	Gobo 4 shake	
		118	127	46.3%	49.8%	Gobo 5 shake	
		128	187	50.2%	73.3%	Gobo wheel continous rotation CW from slow to fast	
		188	195	73.7%	76.5%	Stop	
		196	255	76.9%	100.0%	Gobo wheel continous rotation CCW from slow to fast	
11	Gobo rotating/positioning gobo wheel 1	0	127	0.0%	49.8%	Gobo rotation/positioning	0(0%)
		128	187	50.2%	73.3%	Gobo continous rotation CW from slow to fast	
		188	195	73.7%	76.5%	Stop	
		196	255	76.9%	100.0%	Gobo continous rotation CCW from slow to fast	
12		0	255	0.0%	100.0%	Gobo rotation/positioning, fine (LSB)	
13	Blade up 1	0	255	0.0%	100.0%	White → Full Blade up 1	0(0%)

Standard (35ch)	Name	DMX value		DMX percentage		Function	Default DMX Value
		0	255	0.0%	100.0%	Full Blade up 1, fine (LSB)	
14	Blade up 2	0	255	0.0%	100.0%	White → Full Blade up 2	0(0%)
		0	255	0.0%	100.0%	Full Blade up 2, fine (LSB)	
15	Blade down 1	0	255	0.0%	100.0%	White → Full Blade down 1	0(0%)
		0	255	0.0%	100.0%	Full Blade down 1, fine (LSB)	
16	Blade down 2	0	255	0.0%	100.0%	White → Full Blade down 2	0(0%)
		0	255	0.0%	100.0%	Full Blade down 2, fine (LSB)	
17	Blade left 1	0	255	0.0%	100.0%	White → Full Blade left 1	0(0%)
		0	255	0.0%	100.0%	Full Blade left 1, fine (LSB)	
18	Blade left 2	0	255	0.0%	100.0%	White → Full Blade left 2	0(0%)
		0	255	0.0%	100.0%	Full Blade left 2, fine (LSB)	
19	Blade right 1	0	255	0.0%	100.0%	White → Full Blade right 1	0(0%)
		0	255	0.0%	100.0%	Full Blade right 1, fine (LSB)	
20	Blade right 2	0	255	0.0%	100.0%	White → Full Blade right 2	0(0%)
		0	255	0.0%	100.0%	Full Blade right 2, fine (LSB)	
21	Framing Rotation	0	255	0.0%	100.0%	Framing Rotation	0(0%)
		0	255	0.0%	100.0%	Framing Rotation fine (LSB)	
22	Framing Rotation speed	0	255	0.0%	100.0%	Framing Rotation speed from slow to fast	0(0%)
23	Iris	0	255	0.0%	100.0%	Open → Close	0(0%)
24	Iris macro	0	31	0.0%	12.2%	Disable Iris macro	0(0%)
		32	63	12.5%	24.7%	Effect - Synchronous open from fast to slow	
		64	95	25.1%	37.3%	Effect - Synchronous off from slow to fast	
		96	127	37.6%	49.8%	Effect - Random open from slow to fast	
		128	159	50.2%	62.4%	Effect - Random off from fast to slow	
		160	191	62.7%	74.9%	Strobe follow from slow to fast	
		192	255	75.3%	100.0%	Disable Iris macro	
25	Focus	0	255	0.0%	100.0%	Near → Far	0(0%)
		0	255	0.0%	100.0%	Focus, fine (LSB)	
26	Zoom	0	255	0.0%	100.0%	Narrow → Wide	0(0%)
		0	255	0.0%	100.0%	Zoom, fine (LSB)	
27	Prism	0	31	0.0%	12.2%	Off	0(0%)
		32	255	12.5%	100.0%	On	
28	Prism rotation	0	127	0.0%	49.8%	Prism indexed	0(0%)
		128	187	50.2%	73.3%	Prism continuous rotation CW from slow to fast	
		188	195	73.7%	76.5%	Stop	
		196	255	76.9%	100.0%	Prism continuous rotation CCW from slow to fast	
29	Frost zoom	0	127	0.0%	49.8%	Off	0(0%)

Standard (35ch)	Name	DMX value		DMX percentage		Function	Default DMX Value
		128	255	50.2%	100.0%	Frost zoom from smallest to biggest	
30	Pan	0	255	0.0%	100.0%	Pan	0(0%)
31		0	255	0.0%	100.0%	Pan, fine (LSB)	
32	Tilt	0	255	0.0%	100.0%	Tilt	46(18.0%)
33		0	255	0.0%	100.0%	Tilt, fine (LSB)	
34	Scan speed	0	255	0.0%	100.0%	Scan speed from fast to slow	0(0%)
35	Special controls	0	9	0.0%	3.5%	No function	0(0%)
		10	19	3.9%	7.5%	Open light after 5 seconds	
		20	29	7.8%	11.4%	Close light after 5 seconds	
		30	39	11.8%	15.3%	Color wheel half color switch	
		40	49	15.7%	19.2%	Color wheel random positioning	
		50	59	19.6%	23.1%	Blade motor reset after 5 seconds	
		60	69	23.5%	27.1%	Reset all motor after 5 seconds	
		70	79	27.5%	31.0%	Scan motor reset after 5 seconds	
		80	89	31.4%	34.9%	All color motor reset after 5 seconds	
		90	99	35.3%	38.8%	All gobo motor reset after 5 seconds	
		100	109	39.2%	42.7%	All strobe motor reset after 5 seconds	
		110	119	43.1%	46.7%	Other motor reset after 5 seconds	
		120	129	47.1%	50.6%	Built-in program 1	
		130	139	51.0%	54.5%	Built-in program 2	
		140	149	54.9%	58.4%	Built-in program 3	
		150	159	58.8%	62.4%	Built-in program 4	
		160	169	62.7%	66.3%	Built-in program 5	
		170	179	66.7%	70.2%	Built-in program 6	
		180	189	70.6%	74.1%	Built-in program 7	
190	199	74.5%	78.0%	Built-in program 8			
200	209	78.4%	82.0%	Built-in program 9			
210	219	82.4%	85.9%	Built-in program 10			
220	255	86.3%	100.0%	Voice control			

**DMX protocol - Simplified [32channels]**

Simplified (32ch)	Name	DMX value		DMX percentage		Function	Default DMX Value
1	Strobe/Shutter	0	31	0.0%	12.2%	Closed	0(0%)
		32	63	12.5%	24.7%	Open	
		64	127	25.1%	49.8%	Synchronous strobe from slow to fast	
		128	159	50.2%	62.4%	Open	
		160	223	62.7%	87.5%	Random strobe from slow to fast	
		224	255	87.8%	100.0%	Open	

Simplified (32ch)	Name	DMX value		DMX percentage		Function	Default DMX Value
2	Intensity	0	255	0.0%	100.0%	No light → Full light	0(0%)
		0	255	0.0%	100.0%	Intensity fade, fine (LSB)	
3	Cyan	0	255	0.0%	100.0%	White → Full cyan	0(0%)
		0	255	0.0%	100.0%	Cyan fade, fine (LSB)	
4	Magenta	0	255	0.0%	100.0%	White → Full magenta	0(0%)
		0	255	0.0%	100.0%	Magenta fade, fine (LSB)	
5	Yellow	0	255	0.0%	100.0%	White → Full yellow	0(0%)
		0	255	0.0%	100.0%	Yellow fade, fine (LSB)	
6	CMY color macro	0	15	0.0%	5.9%	CMY color macro off	0(0%)
		16	135	6.3%	52.9%	CMY synchronous color from slow to fast	
		136	255	53.3%	100.0%	CMY random color from slow to fast	
7	CTO	0	255	0.0%	100.0%	Warm → Cold	0(0%)
		0	255	0.0%	100.0%	CTO fade, fine (LSB)	
8	Color wheel	0	15	0.0%	5.9%	Open	0(0%)
		16	31	6.3%	12.2%	Color 1	
		32	47	12.5%	18.4%	Color 2	
		48	63	18.8%	24.7%	Color 3	
		64	79	25.1%	31.0%	Color 4	
		80	95	31.4%	37.3%	Color 5	
		96	111	37.6%	43.5%	Color 6	
		112	127	43.9%	49.8%	Color 7	
		128	187	50.2%	73.3%	Color continous rotation CW from slow to fast	
		188	195	73.7%	76.5%	Stop	
196	255	76.9%	100.0%	Color continous rotation CCW from slow to fast			
9	Gobo wheel (static)	0	15	0.0%	5.9%	Open	0(0%)
		16	23	6.3%	9.0%	Gobo 1	
		24	31	9.4%	12.2%	Gobo 2	
		32	39	12.5%	15.3%	Gobo 3	
		40	47	15.7%	18.4%	Gobo 4	
		48	55	18.8%	21.6%	Gobo 5	
		56	63	22.0%	24.7%	Gobo 6	
		64	71	25.1%	27.8%	Gobo 7	
		72	79	28.2%	31.0%	Gobo 1 shake	
		80	87	31.4%	34.1%	Gobo 2 shake	
		88	95	34.5%	37.3%	Gobo 3 shake	
		96	103	37.6%	40.4%	Gobo 4 shake	
		104	111	40.8%	43.5%	Gobo 5 shake	
		112	119	43.9%	46.7%	Gobo 6 shake	

Simplified (32ch)	Name	DMX value		DMX percentage		Function	Default DMX Value
		120	127	47.1%	49.8%	Gobo 7 shake	
		128	187	50.2%	73.3%	Gobo wheel continous rotation CW from slow to fast	
		188	195	73.7%	76.5%	Stop	
		196	255	76.9%	100.0%	Gobo wheel continous rotation CCW from slow to fast	
10	Rotating gobo wheel 1	0	27	0.0%	10.6%	Open gobo	0(0%)
		28	37	11.0%	14.5%	Gobo 1	
		38	47	14.9%	18.4%	Gobo 2	
		48	57	18.8%	22.4%	Gobo 3	
		58	67	22.7%	26.3%	Gobo 4	
		68	77	26.7%	30.2%	Gobo 5	
		78	87	30.6%	34.1%	Gobo 1 shake	
		88	97	34.5%	38.0%	Gobo 2 shake	
		98	107	38.4%	42.0%	Gobo 3 shake	
		108	117	42.4%	45.9%	Gobo 4 shake	
		118	127	46.3%	49.8%	Gobo 5 shake	
		128	187	50.2%	73.3%	Gobo wheel continous rotation CW from slow to fast	
		188	195	73.7%	76.5%	Stop	
		196	255	76.9%	100.0%	Gobo wheel continous rotation CCW from slow to fast	
11	Gobo rotating/positioning gobo wheel 1	0	127	0.0%	49.8%	Gobo rotation/positioning	0(0%)
		128	187	50.2%	73.3%	Gobo continous rotation CW from slow to fast	
		188	195	73.7%	76.5%	Stop	
		196	255	76.9%	100.0%	Gobo continous rotation CCW from slow to fast	
		0	255	0.0%	100.0%	Gobo rotation/positioning, fine (LSB)	
12	Blade up 1	0	255	0.0%	100.0%	White → Full Blade up 1	0(0%)
		0	255	0.0%	100.0%	Full Blade up 1, fine (LSB)	
13	Blade up 2	0	255	0.0%	100.0%	White → Full Blade up 2	0(0%)
		0	255	0.0%	100.0%	Full Blade up 2, fine (LSB)	
14	Blade down 1	0	255	0.0%	100.0%	White → Full Blade down 1	0(0%)
		0	255	0.0%	100.0%	Full Blade down 1, fine (LSB)	
15	Blade down 2	0	255	0.0%	100.0%	White → Full Blade down 2	0(0%)
		0	255	0.0%	100.0%	Full Blade down 2, fine (LSB)	
16	Blade left 1	0	255	0.0%	100.0%	White → Full Blade left 1	0(0%)
		0	255	0.0%	100.0%	Full Blade left 1, fine (LSB)	
17	Blade left 2	0	255	0.0%	100.0%	White → Full Blade left 2	0(0%)
		0	255	0.0%	100.0%	Full Blade left 2, fine (LSB)	
18	Blade right 1	0	255	0.0%	100.0%	White → Full Blade right 1	0(0%)

Simplified (32ch)	Name	DMX value		DMX percentage		Function	Default DMX Value
		0	255	0.0%	100.0%	Full Blade right 1, fine (LSB)	
19	Blade right 2	0	255	0.0%	100.0%	White → Full Blade right 2	0(0%)
		0	255	0.0%	100.0%	Full Blade right 2, fine (LSB)	
20	Framing Rotation	0	255	0.0%	100.0%	Framing Rotation	0(0%)
		0	255	0.0%	100.0%	Framing Rotation fine (LSB)	
21	Framing Rotation speed	0	255	0.0%	100.0%	Framing Rotation speed from slow to fast	0(0%)
22	Iris	0	255	0.0%	100.0%	Open → Close	0(0%)
23	Iris macro	0	31	0.0%	12.2%	Disable Iris macro	0(0%)
		32	63	12.5%	24.7%	Effect - Synchronous open from fast to slow	
		64	95	25.1%	37.3%	Effect - Synchronous off from slow to fast	
		96	127	37.6%	49.8%	Effect - Random open from slow to fast	
		128	159	50.2%	62.4%	Effect - Random off from fast to slow	
		160	191	62.7%	74.9%	Strobe follow from slow to fast	
		192	255	75.3%	100.0%	Disable Iris macro	
24	Focus	0	255	0.0%	100.0%	Near → Far	0(0%)
		0	255	0.0%	100.0%	Focus, fine (LSB)	
25	Zoom	0	255	0.0%	100.0%	Narrow → Wide	0(0%)
		0	255	0.0%	100.0%	Zoom, fine (LSB)	
26	Prism	0	31	0.0%	12.2%	Off	0(0%)
		32	255	12.5%	100.0%	On	
27	Prism rotation	0	127	0.0%	49.8%	Prism indexed	0(0%)
		128	187	50.2%	73.3%	Prism continuous rotation CW from slow to fast	
		188	195	73.7%	76.5%	Stop	
		196	255	76.9%	100.0%	Prism continuous rotation CCW from slow to fast	
28	Frost zoom	0	127	0.0%	49.8%	Off	0(0%)
		128	255	50.2%	100.0%	Frost zoom from smallest to biggest	
29	Pan	0	255	0.0%	100.0%	Pan	0(0%)
		0	255	0.0%	100.0%	Pan, fine (LSB)	
30	Tilt	0	255	0.0%	100.0%	Tilt	46(18.0%)
		0	255	0.0%	100.0%	Tilt, fine (LSB)	
31	Scan speed	0	255	0.0%	100.0%	Scan speed from fast to slow	0(0%)
32	Special controls	0	9	0.0%	3.5%	No function	0(0%)
		10	19	3.9%	7.5%	Open light after 5 seconds	
		20	29	7.8%	11.4%	Close light after 5 seconds	
		30	39	11.8%	15.3%	Color wheel half color switch	
		40	49	15.7%	19.2%	Color wheel random positioning	
		50	59	19.6%	23.1%	Blade motor reset after 5 seconds	

Simplified (32ch)	Name	DMX value		DMX percentage		Function	Default DMX Value
		60	69	23.5%	27.1%	Reset all motor after 5 seconds	
		70	79	27.5%	31.0%	Scan motor reset after 5 seconds	
		80	89	31.4%	34.9%	All color motor reset after 5 seconds	
		90	99	35.3%	38.8%	All gobo motor reset after 5 seconds	
		100	109	39.2%	42.7%	All strobe motor reset after 5 seconds	
		110	119	43.1%	46.7%	Other motor reset after 5 seconds	
		120	129	47.1%	50.6%	Built-in program 1	
		130	139	51.0%	54.5%	Built-in program 2	
		140	149	54.9%	58.4%	Built-in program 3	
		150	159	58.8%	62.4%	Built-in program 4	
		160	169	62.7%	66.3%	Built-in program 5	
		170	179	66.7%	70.2%	Built-in program 6	
		180	189	70.6%	74.1%	Built-in program 7	
		190	199	74.5%	78.0%	Built-in program 8	
		200	209	78.4%	82.0%	Built-in program 9	
		210	219	82.4%	85.9%	Built-in program 10	
		220	255	86.3%	100.0%	Voice control	

**DMX protocol - Extended [51 channels]**

Extended (51ch)	Name	DMX value		DMX percentage		Function	Default DMX Value
1	Strobe/Shutter	0	31	0.0%	12.2%	Closed	0(0%)
		32	63	12.5%	24.7%	Open	
		64	127	25.1%	49.8%	Synchronous strobe from slow to fast	
		128	159	50.2%	62.4%	Open	
		160	223	62.7%	87.5%	Random strobe from slow to fast	
		224	255	87.8%	100.0%	Open	
2	Intensity	0	255	0.0%	100.0%	No light → Full light	0(0%)
3		0	255	0.0%	100.0%	Intensity fade, fine (LSB)	
4	Cyan	0	255	0.0%	100.0%	White → Full cyan	0(0%)
5		0	255	0.0%	100.0%	Cyan fade, fine (LSB)	
6	Magenta	0	255	0.0%	100.0%	White → Full magenta	0(0%)
7		0	255	0.0%	100.0%	Magenta fade, fine (LSB)	
8	Yellow	0	255	0.0%	100.0%	White → Full yellow	0(0%)
9		0	255	0.0%	100.0%	Yellow fade, fine (LSB)	
10	CMY color macro	0	15	0.0%	5.9%	CMY color macro off	0(0%)
		16	135	6.3%	52.9%	CMY synchronous color from slow to fast	
		136	255	53.3%	100.0%	CMY random color from slow to fast	
11	CTO	0	255	0.0%	100.0%	Warm → Cold	0(0%)



Extended (51ch)	Name	DMX value		DMX percentage		Function	Default DMX Value
12		0	255	0.0%	100.0%	CTO fade, fine (LSB)	
13	Color wheel	0	15	0.0%	5.9%	Open	0(0%)
		16	31	6.3%	12.2%	Color 1	
		32	47	12.5%	18.4%	Color 2	
		48	63	18.8%	24.7%	Color 3	
		64	79	25.1%	31.0%	Color 4	
		80	95	31.4%	37.3%	Color 5	
		96	111	37.6%	43.5%	Color 6	
		112	127	43.9%	49.8%	Color 7	
		128	187	50.2%	73.3%	Color continous rotation CW from slow to fast	
		188	195	73.7%	76.5%	Stop	
		196	255	76.9%	100.0%	Color continous rotation CCW from slow to fast	
14	Gobo wheel (static)	0	15	0.0%	5.9%	Open	0(0%)
		16	23	6.3%	9.0%	Gobo 1	
		24	31	9.4%	12.2%	Gobo 2	
		32	39	12.5%	15.3%	Gobo 3	
		40	47	15.7%	18.4%	Gobo 4	
		48	55	18.8%	21.6%	Gobo 5	
		56	63	22.0%	24.7%	Gobo 6	
		64	71	25.1%	27.8%	Gobo 7	
		72	79	28.2%	31.0%	Gobo 1 shake	
		80	87	31.4%	34.1%	Gobo 2 shake	
		88	95	34.5%	37.3%	Gobo 3 shake	
		96	103	37.6%	40.4%	Gobo 4 shake	
		104	111	40.8%	43.5%	Gobo 5 shake	
		112	119	43.9%	46.7%	Gobo 6 shake	
		120	127	47.1%	49.8%	Gobo 7 shake	
		128	187	50.2%	73.3%	Gobo wheel continous rotation CW from slow to fast	
		188	195	73.7%	76.5%	Stop	
		196	255	76.9%	100.0%	Gobo wheel continous rotation CCW from slow to fast	
15	Rotating gobo wheel 1	0	27	0.0%	10.6%	Open gobo	0(0%)
		28	37	11.0%	14.5%	Gobo 1	
		38	47	14.9%	18.4%	Gobo 2	
		48	57	18.8%	22.4%	Gobo 3	
		58	67	22.7%	26.3%	Gobo 4	
		68	77	26.7%	30.2%	Gobo 5	
		78	87	30.6%	34.1%	Gobo 1 shake	

Extended (51ch)	Name	DMX value		DMX percentage		Function	Default DMX Value
		88	97	34.5%	38.0%	Gobo 2 shake	
		98	107	38.4%	42.0%	Gobo 3 shake	
		108	117	42.4%	45.9%	Gobo 4 shake	
		118	127	46.3%	49.8%	Gobo 5 shake	
		128	187	50.2%	73.3%	Gobo wheel continous rotation CW from slow to fast	
		188	195	73.7%	76.5%	Stop	
		196	255	76.9%	100.0%	Gobo wheel continous rotation CCW from slow to fast	
16	Gobo rotating/positioning gobo wheel 1	0	127	0.0%	49.8%	Gobo rotation/positioning	0(0%)
		128	187	50.2%	73.3%	Gobo continous rotation CW from slow to fast	
		188	195	73.7%	76.5%	Stop	
		196	255	76.9%	100.0%	Gobo continous rotation CCW from slow to fast	
17		0	255	0.0%	100.0%	Gobo rotation/positioning, fine (LSB)	
18	Blade up 1	0	255	0.0%	100.0%	White → Full Blade up 1	0(0%)
19		0	255	0.0%	100.0%	Full Blade up 1, fine (LSB)	
20	Blade up 2	0	255	0.0%	100.0%	White → Full Blade up 2	0(0%)
21		0	255	0.0%	100.0%	Full Blade up 2, fine (LSB)	
22	Blade down 1	0	255	0.0%	100.0%	White → Full Blade down 1	0(0%)
23		0	255	0.0%	100.0%	Full Blade down 1, fine (LSB)	
24	Blade down 2	0	255	0.0%	100.0%	White → Full Blade down 2	0(0%)
25		0	255	0.0%	100.0%	Full Blade down 2, fine (LSB)	
26	Blade left 1	0	255	0.0%	100.0%	White → Full Blade left 1	0(0%)
27		0	255	0.0%	100.0%	Full Blade left 1, fine (LSB)	
28	Blade left 2	0	255	0.0%	100.0%	White → Full Blade left 2	0(0%)
29		0	255	0.0%	100.0%	Full Blade left 2, fine (LSB)	
30	Blade right 1	0	255	0.0%	100.0%	White → Full Blade right 1	0(0%)
31		0	255	0.0%	100.0%	Full Blade right 1, fine (LSB)	
32	Blade right 2	0	255	0.0%	100.0%	White → Full Blade right 2	0(0%)
33		0	255	0.0%	100.0%	Full Blade right 2, fine (LSB)	
34	Framing Rotation	0	255	0.0%	100.0%	Framing Rotation	0(0%)
35		0	255	0.0%	100.0%	Framing Rotation fine (LSB)	
36	Framing Rotation speed	0	255	0.0%	100.0%	Framing Rotation speed from slow to fast	0(0%)
37	Iris	0	255	0.0%	100.0%	Open → Close	0(0%)
38	Iris macro	0	31	0.0%	12.2%	Disable Iris macro	0(0%)
		32	63	12.5%	24.7%	Effect - Synchronous open from fast to slow	
		64	95	25.1%	37.3%	Effect - Synchronous off from slow to fast	
		96	127	37.6%	49.8%	Effect - Random open from slow to fast	

Extended (51ch)	Name	DMX value		DMX percentage		Function	Default DMX Value
		128	159	50.2%	62.4%	Effect - Random off from fast to slow	
		160	191	62.7%	74.9%	Strobe follow from slow to fast	
		192	255	75.3%	100.0%	Disable Iris macro	
39	Focus	0	255	0.0%	100.0%	Near → Far	0(0%)
40		0	255	0.0%	100.0%	Focus, fine (LSB)	
41	Zoom	0	255	0.0%	100.0%	Narrow → Wide	0(0%)
42		0	255	0.0%	100.0%	Zoom, fine (LSB)	
43	Prism	0	31	0.0%	12.2%	Off	0(0%)
		32	255	12.5%	100.0%	On	
44	Prism rotation	0	127	0.0%	49.8%	Prism indexed	0(0%)
		128	187	50.2%	73.3%	Prism continous rotation CW from slow to fast	
		188	195	73.7%	76.5%	Stop	
		196	255	76.9%	100.0%	Prism continous rotation CCW from slow to fast	
45	Frost zoom	0	127	0.0%	49.8%	Off	0(0%)
		128	255	50.2%	100.0%	Frost zoom from smallest to biggest	
46	Pan	0	255	0.0%	100.0%	Pan	0(0%)
47		0	255	0.0%	100.0%	Pan, fine (LSB)	
48	Tilt	0	255	0.0%	100.0%	Tilt	46(18.0%)
49		0	255	0.0%	100.0%	Tilt, fine (LSB)	
50	Scan speed	0	255	0.0%	100.0%	Scan speed from fast to slow	0(0%)
51	Special controls	0	9	0.0%	3.5%	No function	0(0%)
		10	19	3.9%	7.5%	Open light after 5 seconds	
		20	29	7.8%	11.4%	Close light after 5 seconds	
		30	39	11.8%	15.3%	Color wheel half color switch	
		40	49	15.7%	19.2%	Color wheel random positioning	
		50	59	19.6%	23.1%	Blade motor reset after 5 seconds	
		60	69	23.5%	27.1%	Reset all motor after 5 seconds	
		70	79	27.5%	31.0%	Scan motor reset after 5 seconds	
		80	89	31.4%	34.9%	All color motor reset after 5 seconds	
		90	99	35.3%	38.8%	All gobo motor reset after 5 seconds	
		100	109	39.2%	42.7%	All strobe motor reset after 5 seconds	
		110	119	43.1%	46.7%	Other motor reset after 5 seconds	
		120	129	47.1%	50.6%	Built-in program 1	
		130	139	51.0%	54.5%	Built-in program 2	
		140	149	54.9%	58.4%	Built-in program 3	
		150	159	58.8%	62.4%	Built-in program 4	
160	169	62.7%	66.3%	Built-in program 5			
170	179	66.7%	70.2%	Built-in program 6			

Extended (51ch)	Name	DMX value		DMX percentage		Function	Default DMX Value
		180	189	70.6%	74.1%	Built-in program 7	
		190	199	74.5%	78.0%	Built-in program 8	
		200	209	78.4%	82.0%	Built-in program 9	
		210	219	82.4%	85.9%	Built-in program 10	
		220	255	86.3%	100.0%	Voice control	

**⚠Notes**

Do not switch off the fixture within the first minute after switching on. Wait for at least 5 minutes to switch on the fixture.

**Technical specification**

**Optical**

- Light source: OSRAM SHARXS® 1500W Brilliant (OSRAM SHARXS HTI 1500W/D7/60 or PHILIPS MSR Gold 1510 SA/DE optional)
- Expected average lifetime: 750 hours
- Beam angle (zoom): 12°- 52°
- Focus: Variable range, from 5m to infinity
- Prism: 3-facet prism, CW/CCW rotation, variable speed
- Ballast: Electronic

**Photometric**

- Total Output (Lumen): 25200 lumens narrow / 25700 lumens wide

**Gobo**

- Rotating gobo: 5 interchangeable gobos + open, indexing, CW/CCW rotation, variable speed
- Static gobo wheel: 7 gobos + open, CW/CCW rotation, variable speed
- Gobo outside diameter: 33mm
- Max. Image diameter: 27mm
- Max. Thickness: 0.5mm(Metal)/1mm(Glass)
- Glass/Metal gobo: Glass/Metal

**Color**

Color wheel: 7 colors + open, split color, CW/CCW rotation, variable speed

CMY / CTO: CMY + CTO for linear infinity color mixing

**Electrical**

- Power input, nominal: AC 200-240V, 50/60Hz
- Max. Power consumption: 1912W, max current: 8.7A, PF: 0.98
- Power supply unit: Auto-ranging electronic SMPS
- Main fuse: 250V/15A

**Control and programming**

- Control channels (DMX): 35/32/51
- Protocol: DMX-512
- Display: Graphic LCD backlit

**Physical / Installation**

- Weight: 48 kg (105 lbs.)
- IP rating: IP20
- Material: Aluminum, steel, plastic
- Mounting points: Four quarter-turn locking points + attachment points for safety wire
- Minimum distance to combustible materials: 0.5 m (1.64ft.)
- Minimum distance to illuminated surfaces: 3 m (9.84ft.)

**Dynamic effects**

- Pan/Tilt movement: 540°/270°
- Iris: 5-100% high speed, with build-in macros
- Strobe: 1-20Hz, synchronized, pulse effects
- Dimmer: 0-100%, 16-bit, mechanical dimming
- Framing: Rotating module +/- 45°, 4 shutter blades, full crossover of each blade, angle of each blade +/-45°

**Thermal**

- Operating range: 14°F to 113°F (-10°C to +45°C)
- Startup range: 5°F to 113°F (-15°C to +45°C)
- Storage range: -40°F to 140°F (-40°C to +60°C)
- Cooling: Active fan
- Humidity: ≤85%

**Connections**

- AC power: Neutrik powerCon
- DMX data input/output: Chassis 5-pin Neutrik XLR (in/out)

**Certification and Safety**

- EMC: EN 55103-1:2009, EN 55103-2:2009, EN 61000-3-2:2006+A2:2009, EN 61000-3-3:2013
- Safety: EN 60598-2-17:1989/A2:1991

**Photometric**

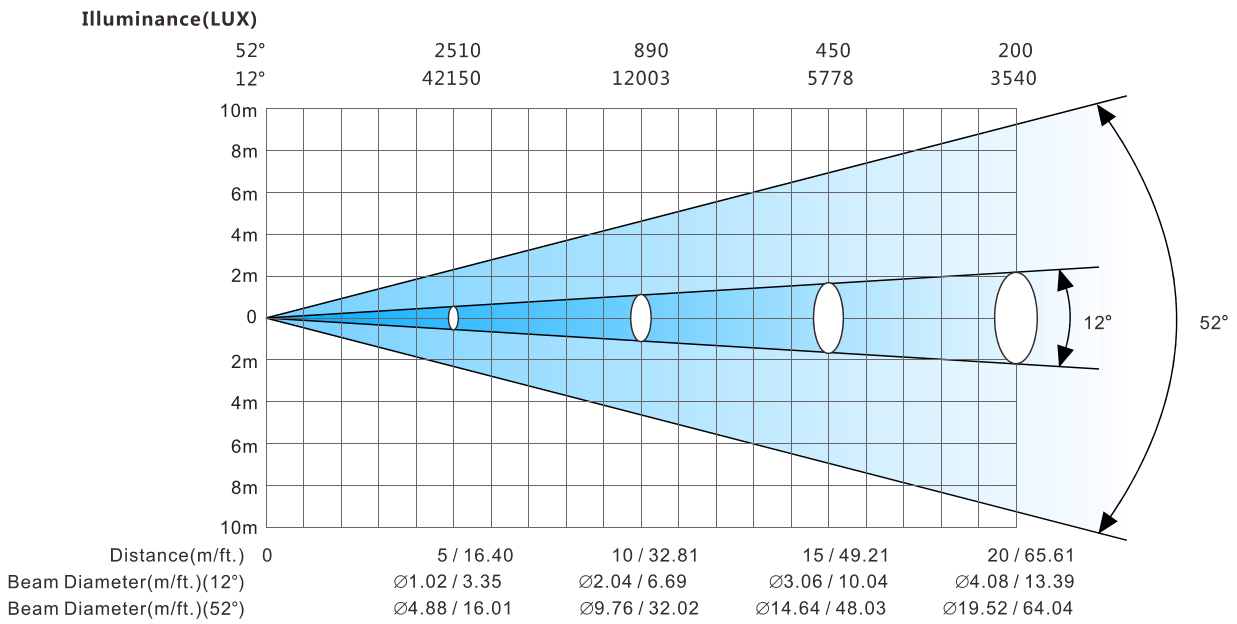

**Other features**

- Enhanced stability of the fixture due to the wide input voltage AC/DC switching power supply which both reduces the impact of power and voltage fluctuations, and removes the restriction of voltage and frequency variations in different countries.
- Automatic energy saving: when the shutter or CMY is closed, power consumption will be reduced automatically with the photoelectric tracking induction technology.
- Sleep mode: uses the most advanced technology to remotely activate sleep mode. When the fixture is disconnected from signal, the sleep mode is enabled automatically to make it more stable and safer. Sleep time can be customized.
- Power setting: built-in continuous rechargeable battery, allowing setting functional data via LCD interface without power connection
- Communication design: DMX wired or wireless signal transmission, RDM bi-directional control technology, can be upgraded by DMX remote software.

## Cleaning and maintenance

It is required that the fixture should be kept clean and well maintained to ensure its reliability. Its lifespan mainly depends on the working environment and proper operation. Should you have any questions, please consult a technical engineer of GTD Lighting.

### Notes

Damage resulted from dust, smoke, oil or improper use is not covered by warranty.

### Warning

Disconnect the fixture from AC power, and let it cool down for at least 15 minutes before opening the housing. Make sure to use a soft cloth to clean the optical components, and be careful, as the coating is easily scratched. Do not use any organic solvent such as alcohol to clean the reflector mirror, dichroic color filters or housing of the fixture.

- If the lens is cracked or otherwise damaged, replace it immediately.
- If the lamp becomes damaged or deformed in any way it must be replaced.
- If the light from the lamp appears dim, this normally indicates that it is reaching the end of its life span and should be changed at once. Aged lamps run to the extremity of their life might explode.
- If fixture does not function, check the fuse on the power socket of the fixture. Replace the fuse of the same specification if it is blown.
- The fixture is equipped with thermal-protection device that will switch off the lamp in case of overheating. If this happens, please check that the fans are not blocked, and clean them if they are dirty. Check whether the fans are operational. If not, call a qualified technician. Troubleshoot and correct the problem before switching on the fixture again. Any maintenance work should only be carried out by qualified technicians.
- To ensure the continuous rotation of the rotating gobos and linear motion of the focus lens, it is recommended that the bearings on the rotating gobos and the 2 shafts for the focus system are lubricated periodically, preferably every 3-6 months. Use only high quality, high-temperature resistant grease. When lubricating the bearings, a syringe with a fine needle is the best way to grease the bearings around each gobo. Be aware not to use too much grease, and stain the parts around.

## Troubleshooting

Problem	Possible Cause	Suggested Correction
No response after connected to A/C power	Power switch not turned on.	Turn on power switch.
	Take out the fuse and check if it is blown.	Locate the blown fuse. Remove the broken fuse. Insert a replacement fuse of the correct amperage.
	Abnormal A/C input (A/C power socket, power cables, luminaire power socket).	Replace AC power socket and power cables, and then adjust power socket for proper connection.
	No DC voltage from switching power supply.	Check if the switching power supply has DC voltage output. Replace the switching power supply.
No response or wrong response to the commands of the control system	DMX cables disconnected from fixture's DATA IN connector.	Connect DMX cable to the fixture's DATA IN connector.
	Open circuit or short circuit fault in the DMX cables.	Replace DMX cables as required.
	Wrong DMX address for the fixture in the control system.	Ensure the address in "Run setting > Address Setting > Address" of the fixture is consistent with the address in the control system.
	Misuse in "Channel setting > Channel Mode" of the fixture.	Choose the channel mode in "Channel setting > Channel Mode" of the fixture as required by the user.
	Malfunctioning of DMX cannon input/output connectors. No input/output voltage to the main control board of the fixture.	Troubleshooting the DMX XLR signal plate of the fixture, replace the main control board of the fixture.
The lamp does not start when switch is turned on	Normal end of lamp life.	Test the lamp in an adjacent fixture which is known to be operating properly and then replace as necessary.
	Whether the function of the relay board is intact, whether the signal is normal or not.	Repair or replace.
	Shorted leads between ballast and the lamp.	Replace components as required.
	Incorrect ballast output.	Check ballast output to determine if it conforms to lamp requirements. If voltage and current do not stabilize in five to ten minutes warm-up time, ballast output is incorrect and adjustment should be made. Check capacitor wiring, if visibly available, to determine if capacitors are properly wired.
	Incorrect triggers output.	Replace triggers.
The lamp is off unexpected	The fixture is in sleep mode.	Should the fixture is not in active use for "standby time", the sleep mode is enabled automatically to make it more stable and safer, sleep time can be customized.
	Lamp has been operating: cool down time insufficient.	Environmental conditions such as extreme temperatures will have the fixture stop working, the lamps will require a period of time to cool and re-establish optimum starting conditions. Restart time varies with the degree of ventilation built into it, ambient temperature, and draft conditions.
	Overheat ballast resulting in premature failure or damaged ballast.	The ballast incorporate internal automatic-resetting thermal protection, which deactivates the ballast should it overheat. Normal operation resumes once the ballast has cooled sufficiently. Burned-out or failing lamps, or high temperatures in or around the fixture, can cause the ballast to overheat, so we need solve the problem and replace components as required.
	Thermostat damaged.	Replace.



<b>Problem</b>	<b>Possible Cause</b>	<b>Suggested Correction</b>
Shaking, wrong position, and out of control gobo wheel	No function the connector between gobo wheel motor and drive, loose, damaged, or broken cables connecting the gobo wheel and drive.	Reconnect the gobo wheel motor to the drive, and replace cables as required.
	The gobo wheel motor's drive IC on the PCB might be out of condition.	Replace the drive having the same software version as required.
	Dislocated magnetic tube and positioning magnet, or damaged magnetic tube.	Calibrate the position of the magnetic tube to the positioning magnet, and replace magnetic tube as required.
	Shaking motor, wrong rotation angle, losing step or damaged motor.	Replace the motor as required.
Decreased brightness, uneven pattern projections	Normal end of lamp life.	Test the lamp in an adjacent fixture which is known to be operating properly and then replace as necessary.
	The midline of the lamp is not aligned with the center point of the effect assembly (consisting of the rotating gobo wheel, static gobo wheel, color wheel, strobe, prism, and frost), focus module, and objective lens.	Reinstall the lamp. Adjust the lamp position until the midline of the lamp is aligned with the center point of the effect assemblies (consisting of the rotating gobo wheel, static gobo wheel, color wheel, strobe, prism, frost, the focus adjusting module, and the object lens).
	Excessive dusts or smudges on the effect assembly, focus module and objective lens.	Follow the instructions stated in this user manual to clean the effect assembly, focus module and objective lens.
	Damaged or deformed effect assembly, focus module or objective lens.	Replace the damaged or deformed components.
Wrong color	Normal end of lamp life.	Test the lamp in an adjacent fixture which is known to be operating properly and then replace as necessary.
	Excessive dusts or smudges on the rotating gobo wheel or color wheel.	Follow the instructions stated in this user manual to clean the rotating gobo wheel or color wheel.
	Rotating gobo wheel, color wheel with coating wearing off, damages or deformation.	Replace the worn-off, damaged or deformed rotating gobo wheel and color wheel.
Non-clear shape	Excessive dusts or smudges on the rotating gobo wheel or color wheel.	Follow the instructions stated in this user manual to clean the rotating gobo wheel or color wheel.
	Excessive dusts or smudges on the focus module or objective lens.	Follow the instructions stated in this user manual to clean the focus module or objective lens.
	Damaged or deformed focus module or objective lens.	Replace the damaged or deformed focus module or objective lens.

System wiring diagram

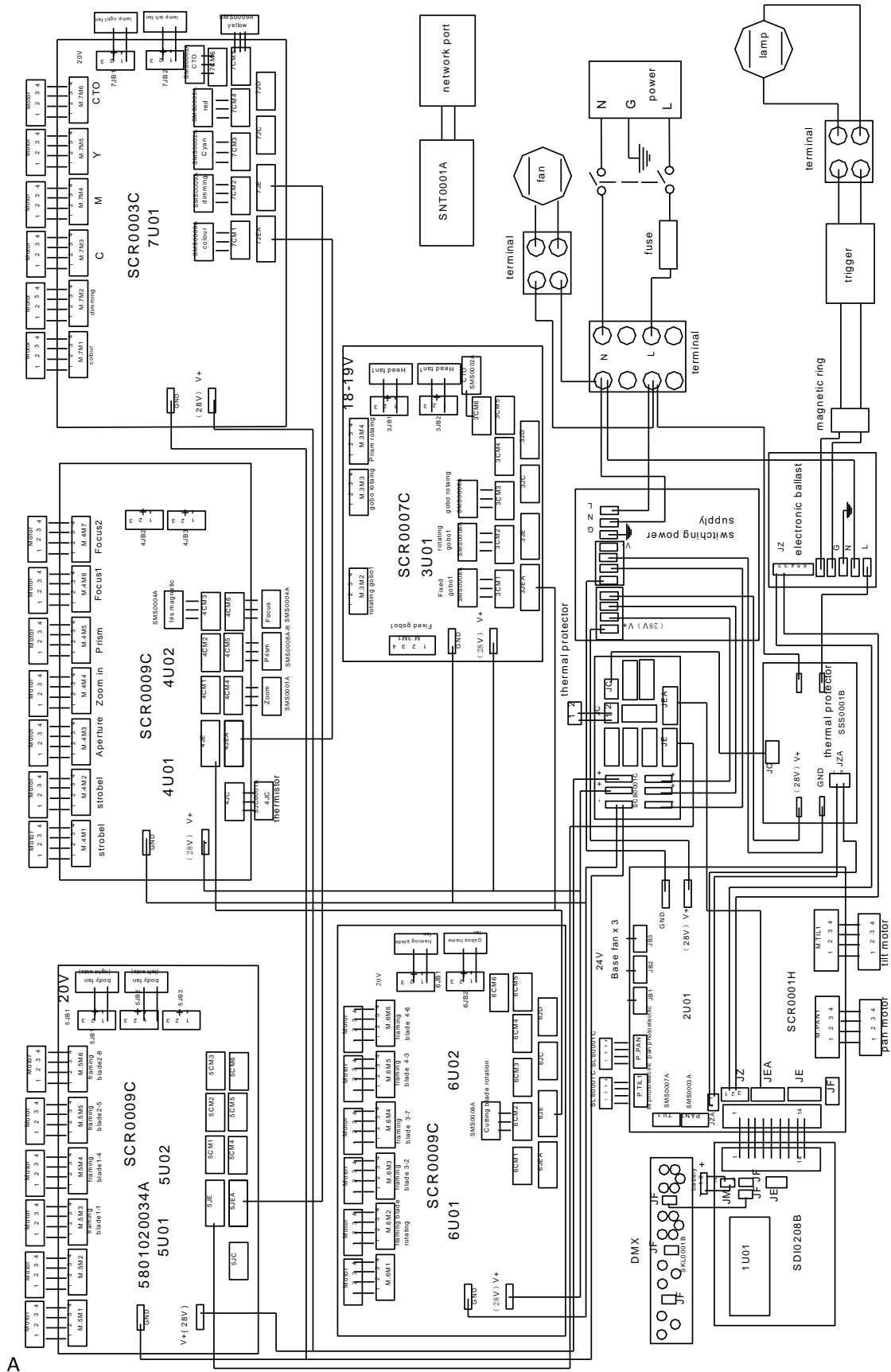

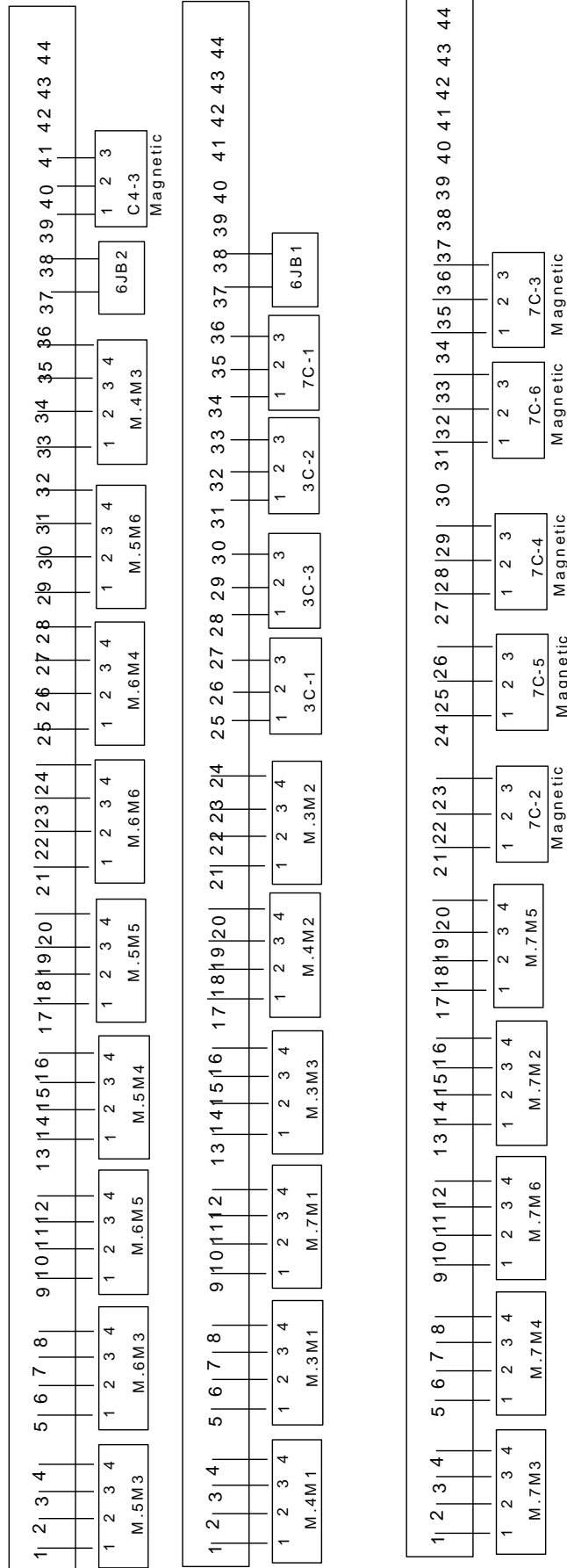

**Spare parts list**

Item	P/N	Qty	Notes
Display board	5809010195C	1	1500NPF-101A20 SDI0208E
Scanning board	5809010194A	1	1500NPF-201B20 SCR0206B
Motor drive board3	5809010196A	1	1500NPF-301C20 SCR0007D
Motor drive board 4	5809010197A	1	1500NPF-401B20&402B20 SCR0216C
Motor drive board 5	5809010198A	1	1500NPF-501B20&502B20 SCR0216C
Motor drive board 6	5809010199A	1	1500NPF-601B20&602B20 SCR0216C
Motor drive board 7	5809010200A	1	1500NPF-701C20 SCR0003D
Switching Power Supply	1412050001A	1	350W POWER MODEL:ESE350-28

**Appendix 1**

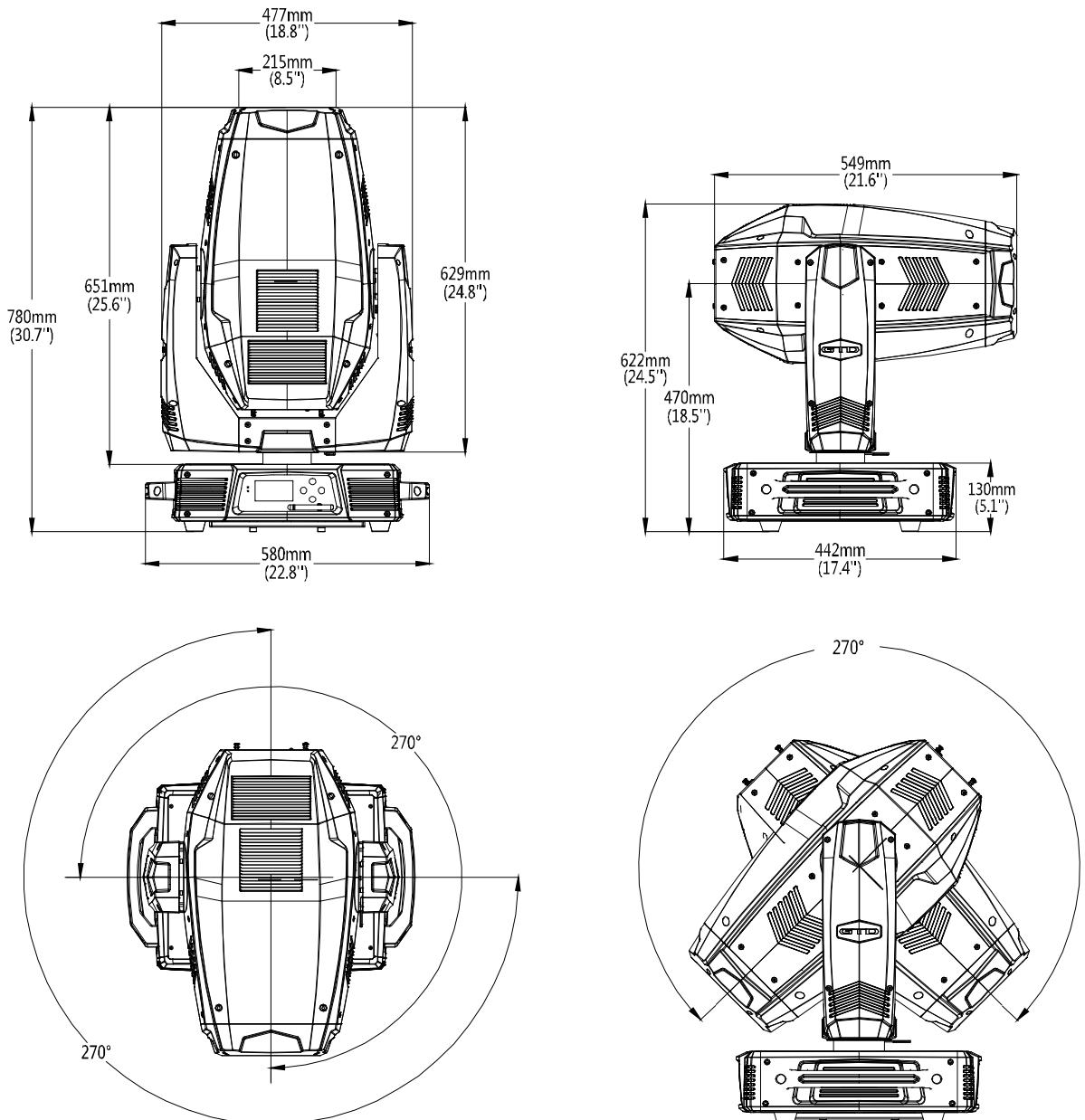

Notes:

Time: January 19<sup>th</sup>, 2017