

# TUNGDOU

**Moving Head  
(beam-spot-wash)**

**TD-350 BSW**

**User's Manual**

**Guangzhou GTD Lighting Technology Co., Ltd.**

Tel: +86-20-61808296

Fax: +86-20-61812282

<http://www.gtd-lighting.com>







©2018 GTD all rights reserved. Information, specifications, diagrams, images, and instructions herein are subject to change without notice. GTD logo and identifying product names and numbers herein are trademarks of GTD. Copyright protection claimed includes all forms and matters of copyrightable materials and information now allowed by statutory or judicial law or hereinafter granted. Product names used in this document may be trademarks or registered trademarks of their respective companies and are hereby acknowledged. All non-GTD brands and product names are trademarks or registered trademarks of their respective companies.

GTD and all affiliated companies hereby disclaim any and all liabilities for property, equipment, building, and electrical damages, injuries to any persons, and direct or indirect economic loss associated with the use or reliance of any information contained within this document, and/or as a result of the improper, unsafe, insufficient and negligent assembly, installation, rigging, and operation of this product.

## Contents

<b>Safety instructions</b> .....	<b>4</b>
<b>General guidelines</b> .....	<b>5</b>
<b>Packing and shipping</b> .....	<b>6</b>
Protection lock.....	6
Unpacking .....	6
Packing after use.....	6
<b>Accessories</b> .....	<b>6</b>
<b>Product introduction</b> .....	<b>7</b>
<b>Installation</b> .....	<b>8</b>
Clamps installation .....	8
Device installation .....	8
<b>Lamp fitting and adjustment</b> .....	<b>9</b>
<b>Power / Control connection</b> .....	<b>10</b>
Power connection .....	10
Control connection .....	10
Testing .....	10
<b>Control panel</b> .....	<b>11</b>
<b>Gobos and colors</b> .....	<b>11</b>
Gobo specification .....	11
Gobos.....	12
Colors.....	12
<b>Menu structure</b> .....	<b>13</b>
<b>DMX protocol</b> .....	<b>17</b>
<b>Technical specification</b> .....	<b>22</b>
<b>Cleaning and maintenance</b> .....	<b>25</b>
<b>Troubleshooting</b> .....	<b>26</b>
<b>System wiring diagram</b> .....	<b>28</b>
<b>Spare parts list</b> .....	<b>29</b>
<b>Appendix 1</b> .....	<b>29</b>

## Safety instructions

	<p><b>WARNING!</b></p> <p>Before using the fixture, read the latest version of the product user manual, paying particular attention to the safety instructions. Please check <a href="http://www.gtd-lighting.com">www.gtd-lighting.com</a> for the latest revision/update of the user manual. The manufacture of this fixture, are not responsible for damages, resulting from misuse of this fixture, due to the disregard of the information printed in this user manual.</p>
	<p><b>DANGER!</b></p> <p>Hazardous voltage. Risk of lethal or severe electric shock.</p>
	<p><b>WARNING!</b></p> <p>Burn hazard. Hot surface. Do not touch.</p>
	<p><b>WARNING!</b></p> <p>Fire hazard.</p>
	<p><b>INDOORS USE ONLY!</b></p> <p>Do not expose fixture for rain and moisture.</p>
	<p>It's essential that the fixture is properly grounded. Only qualified personnel should perform electrical connections.</p>
	<p><b>WARNING!</b></p> <p>Wear protective eyewear. Never look directly into the light source.</p>

- Only qualified and certified personnel should perform installation of this fixture and only the original rigging parts (brackets) included with this fixture should be used for installation.
- Before applying power to the fixture, check that the source voltage matches the fixture's requirement. Every fixture must be earthed (grounded) and installed in accordance with local electricity regulations. Do not connect it to a dimmer system.
- Never look directly into the light source of this fixture to prevent risk of injury to your retina, which may induce blindness.

## General guidelines

- Never open this fixture while in use.
- The fixture should be kept clean. **DO NOT** operate the fixture in extreme heat or dusty environments. Avoid contact with chemical liquid.
- This fixture is a professional light effect designed for **INDOOR / DRY LOCATIONS ONLY** on stage, in nightclubs, theatres, etc.
- **Minimum** distance to lighted objects must be **26.25feet (8m)**.
- **Maximum** temp of the external surface **194°F (90°C)**.
- **Maximum** ambient temperature **113°F (45°C)**.
- **Minimum** distance of inflammable materials from the surface **1.6 feet (0.5m)**.
- Lamp should be changed if damaged or distorted in shape due to extreme heat.
- The light source of the fixture should be changed by the manufacture or its service agent or certified technicians. WARNING! Risk of electric shock. 
- The basic insulation should be kept between the controllable device and the power supply.
- Cover, prism or LCD Menu Function Display with visible damages such as cracks or scratches must be replaced to ensure performance of the fixture.
- Disconnect the fixture from power before changing any parts or accessories.
- Make sure that the installation area can hold a minimum point load of 10 times the weight of all installed fixtures, clamps, cables, auxiliary equipment, etc. Check that the cover, clamps and locks are undamaged. Certified safety cables must always be used when installing the fixture.
- The fixture is only intended for installation, operation and maintenance by qualified professional. Instructions stated in the manual must be complied.
- The fixture must be kept in a well-ventilated place at least 50 cm away from any wall surface. Check if the fans or ventilation openings are unblocked.
- This fixture uses discharge lamp. To avoid reducing the lamp's life, wait at least 15 minutes after powering off to allow the unit to cool down before handling.
- Broken or damaged cables can only be fixed or changed by certified technicians, certified local distributors or the manufacturer to ensure operational safety.
- Do not stick filters or other materials onto the lens. Do not modify the fixture or install other than GTD manufactured parts.
- For questions regarding safety operation, please contact our technical personnel or call the service hotline +8620 61808296.

## Packing and shipping

### Protection lock

Pan and tilt locks are equipped to ensure safe transportation.

PAN: 4 lock positions are located evenly on the Pan.

TILT: 3 lock positions are located on left and right side of the Tilt with the third one in the center.

### Unpacking

#### Notes

All products are quality controlled and checked for any faults before they are dispatched to customers. If the fixture is damaged during delivery, the customer must notify the shipper and manufacturer to file a damage insurance claim. Photographic evidence of the damage must be provided.

#### Flight-Case

Size: 102\*58\*77cm, 2 units/box

Open the cover of the flight-case and remove the plastic packing bags. Hold the handles of the fixture firmly and take it out carefully.

#### Cardboard box

Size: 57\*47\*63cm, 1 unit/box

Open the box and take out the whole set of packaging foam which contains both the fixture and its accessories. Remove the foam from the top, put away the accessories, and then take out the fixture wrapped in the plastic bag.

#### Notes

Check if the pan and tilt are unlocked before connecting the fixture to power.

## Packing after use

1. Switch off the fixture and wait for at least 5 minutes before disconnecting it from AC power. Cool down the fixture for at least 15 minutes before packing.
2. Lock pan and tilt.
3. Flight case: Wrap the fixture in plastic bags. Hold it by the handles, and then carefully place it inside the flight case along with all the accessories. Close the cover. Only 2 layers are allowed when piling up the flight cases. Do not upside down.  
Cardboard box: Wrap the fixture in plastic bags. Put it in the packaging foam along with all the accessories. Place the other set of packaging foam on top then carefully put it inside the cardboard box.

## Accessories

Item	Qty	Unit	Notes
User Manual	1	pc	
Clamps	2	set	Straight type 154*1358*25mm Ø50*30KG
Safety cable	1	pc	Ø4*60cm 7*19 strands with hook material: steel;
3-Core Signal cable	1	Set	5m

#### Notes

Accessories are subject to change without any prior written notice.

Product introduction

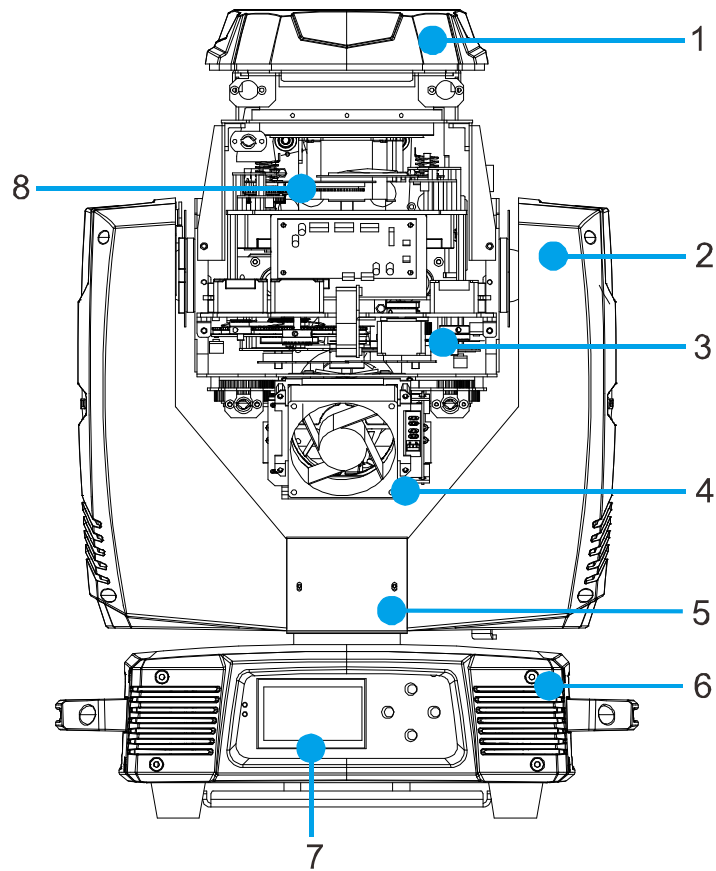

- |   |               |   |                       |   |                              |
|---|---------------|---|-----------------------|---|------------------------------|
| 1 | Head assembly | 2 | Tilt                  | 3 | Color & gobo wheels assembly |
| 4 | Lamp source   | 5 | Pan                   | 6 | Base                         |
| 7 | Display       | 8 | Focus, prism assembly |   |                              |

## Installation

### Clamps installation

The fixture can be placed on the stage or mounted on the truss facing any direction. Attach the clamps to the mounting position on the base of the fixture.

#### Warning

Use two clamps when mounting the fixture. Turn the screws attached to each clamp a 1/4 turn clockwise to lock. Always remember to use the safety cable which goes through the mounting hole on the base. Do not attach the safety cable on the handle.

### Device installation

1. Make sure there is no damage on the clamps or safety cables before installation.
2. The clamp is mounted on the chassis of the fixture. Horizontally insert the clamp into the mounting holes of the chassis. Fasten the clamp tightly by a 1/4 turn clockwise. Fix another clamp in the same way.
3. Check if pan and tilt are unlocked before connecting the unit to AC power.

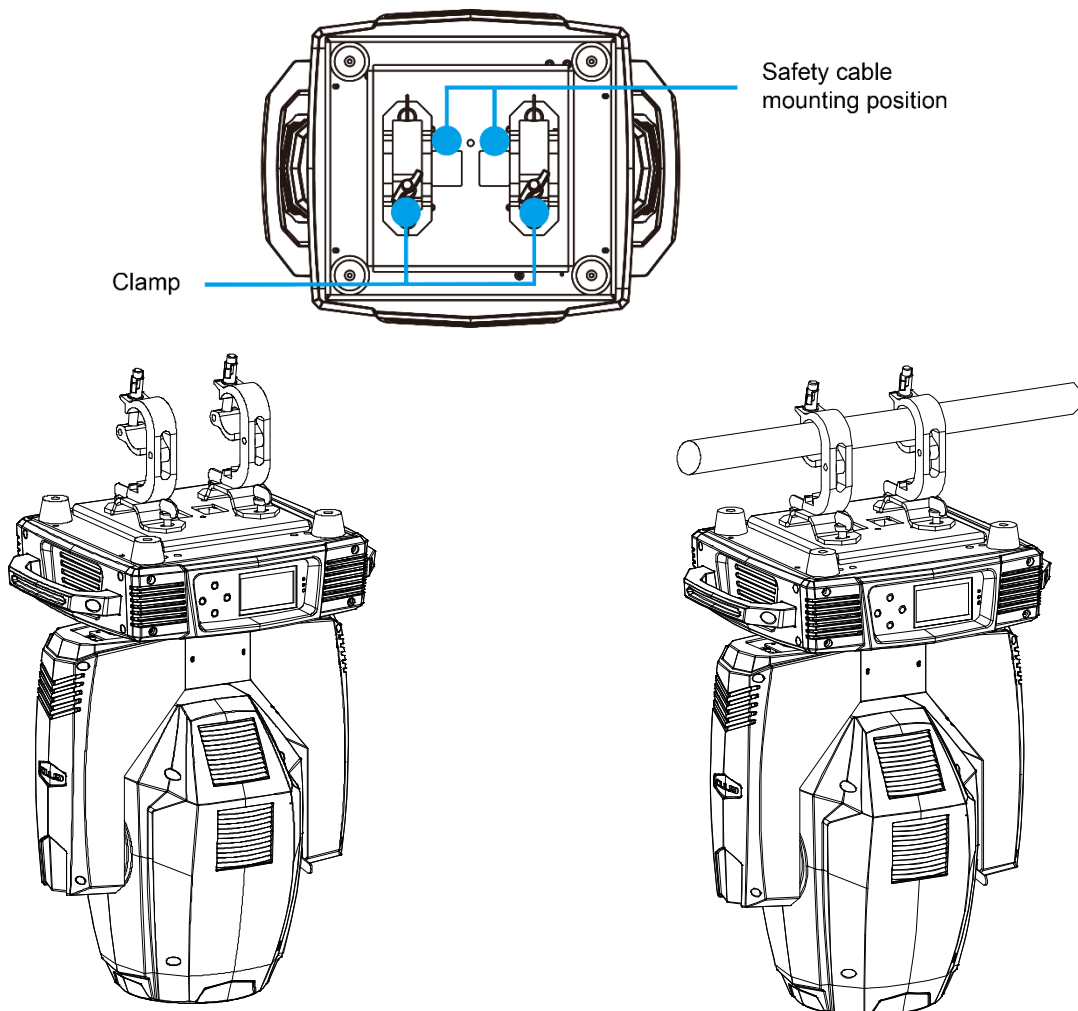

## Lamp fitting and adjustment

1. Disconnect the fixture from AC power. Allow the fixture to cool down for at least 15 minutes. Put the Tilt lock-catch in the horizontal position.
2. Dismounting the lamp (see below): remove the top cover of the shell first, and then the bulb cooling fans. Loosen the two screws of the bulb springy retainer. Pull up the springy retainer by one hand and push the lamp by the other, then we can slowly pull the lamp out.

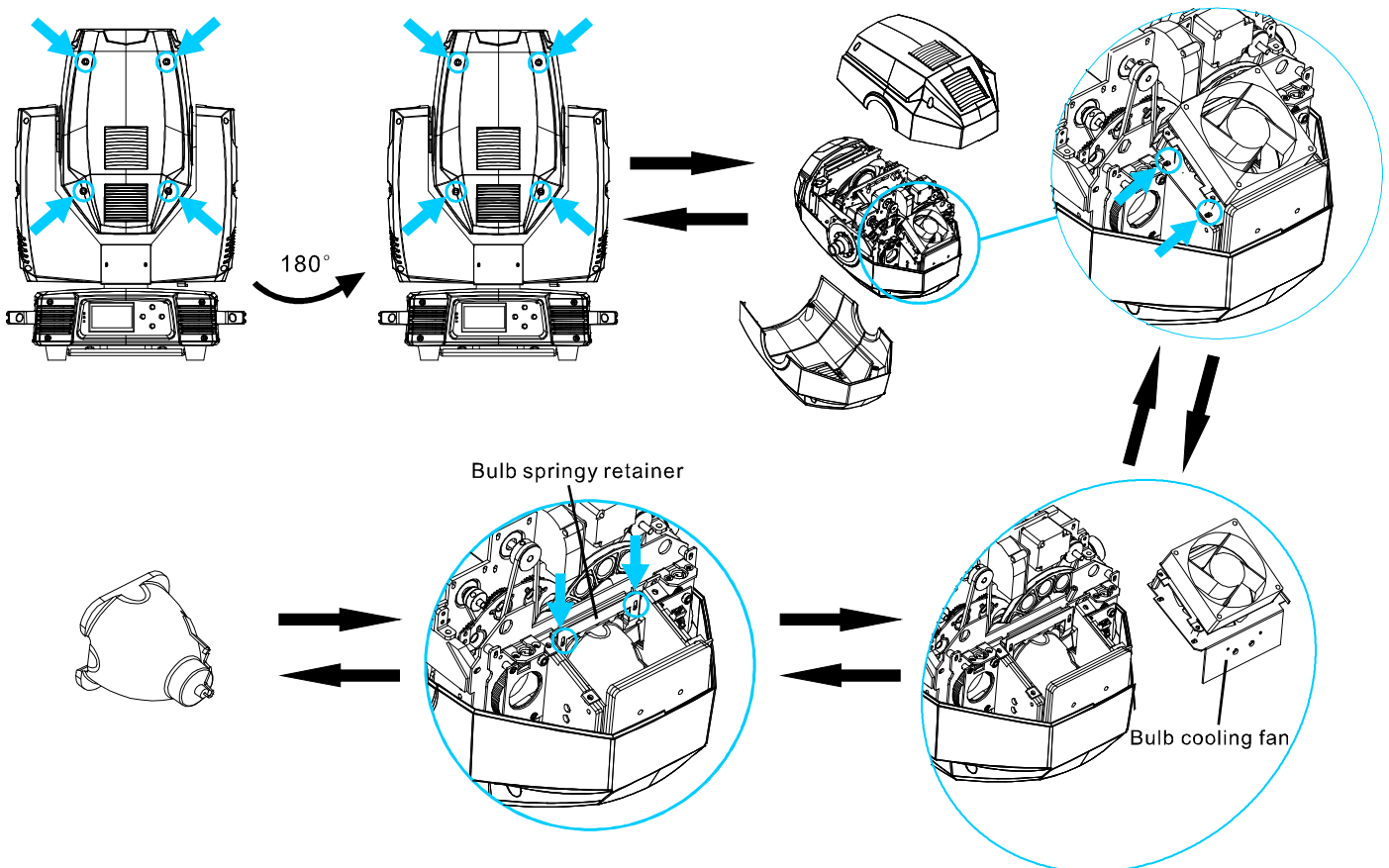

3. Installing the lamp (see above): Pull up the bulb springy retainer, then carefully insert the lamp inside, fasten the two screws of the bulb springy retainer. Install the cooling fans as well as the cover shell.
4. Make sure the new bulb is installed in the right position on the holder and the mounting holes are fixed, and the midline of the lamp is aligned with the center point of the effect assembly (consisting of the rotating gobo wheel, static gobo wheel, color wheel, strobe, prism, and frost), focus module, and object lens.

### ⚠Notes

The fixture uses MSD Platinum 16 R, featuring low power consumption and high performance with a stable 6400K color temperature. Its average life span is 1500 hours.

### ⚠Warning

Fitting another type of lamp will cause potential damage to the fixture. Change the lamp before it reaches its lifespan. Read the guidelines in the package carefully when fixing the lamp.

To avoid any impact on the beam, do not touch the bulb with your bare hands. The lamp must be kept clean with the use of the clean paper contained in its package.

## Power/ Control connection

### Power connection

Connection method:

- L (Live) Brown wire
- E (Earth) Yellow / Green bi-color wire
- N (Neutral) Blue wire
- The voltage and frequency of the power source must be in compliance with the ones marked on the fixture. It is strongly recommended that each fixture are to be connected to the power source separately so that they can be switched on / off individually.

### !Notes

It is essential that each fixture is correctly grounded and the electrical installation conforms to all relevant Standards / Codes of Practice for Safe Electrical Work.

### Control connection

The fixture has 5-pin XLR connectors for DMX data input and output (3-pin optional) as shown below. Connection between the console and fixture, and between fixtures must be made with 2 core screened DMX signal cable. Maximum connecting distance of signal cable is 150 meters. Additional DMX512 signal-amplifier are recommended for longer distance.

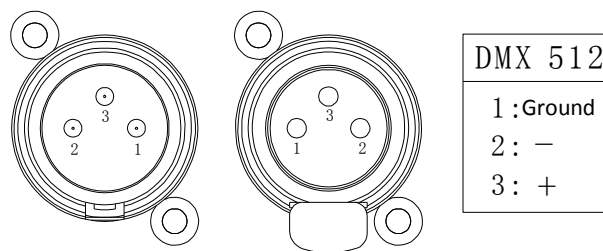

Connect the Console's DMX OUTPUT to the first fixture's DMX INPUT, then the first fixture's DMX OUTPUT to the second fixture's DMX INPUT and so on. It is recommended not to connect more than 32 units on a single DMX universe. On the last fixture's output connect a DMX terminator. (The terminator is a XLR connector with a ¼ W and 120Ω resistor between the pin 2 and pin 3) as shown below:

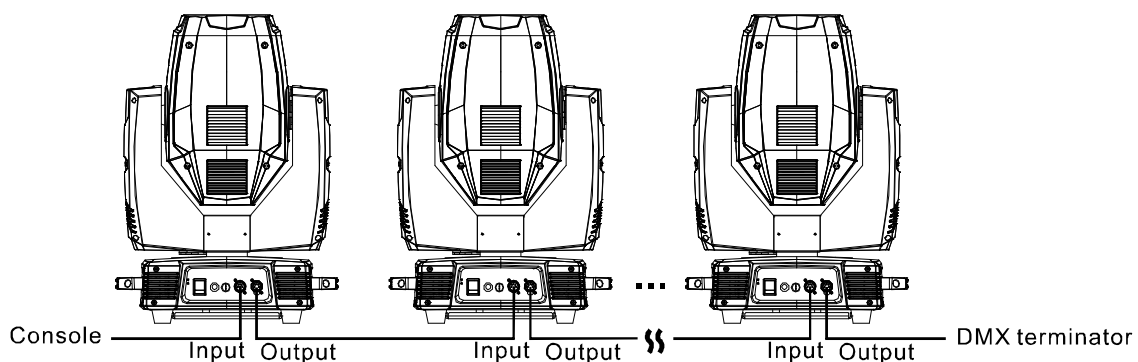

### Testing

Connect the fixture to AC power. Check if the lamp is on and the fixture is independently controllable before putting into operation.

## Control panel



- The control panel features touch-sensitive buttons and LCD digital display for quick and easy setup of address code and functions menu.
- Press UP or DOWN to view or select the function menu.
- Press ENTER to choose a function and enter into corresponding sub menu. Each menu represents a specific function of the fixture.
- Press ENTER to select the specific function and save the changes or enter into the submenu, then press UP or DOWN to change the value of the selected function (increase or decrease).
- Press MENU to return to the previous menu or exit.
- LED indicators:
  - Power on: RED power LED indicator on
  - Signal on: Green DMX indicator on
  - No Signal: Green DMX indicator off

## Gobos and colors

### Gobo specification

All patterns are made onto the metal gobos, and can be customized according to user's requirement. The customized size is as below:

Gobo material	Outer dimension	Effective dimension	Thickness
Metal gobo	∅ 14.4mm	∅ 7.0mm	∅ 0.3mm

#### Notes

Metal Gobo is made of high temperature resistant aluminum alloy in laser cutting.

## Gobos

- One rotating gobo wheel: 8 interchangeable gobos + open, indexing, CW/CCW rotation, variable speed
- One fixed gobo wheel: 11 gobos + open, CW/CCW rotation, variable speed

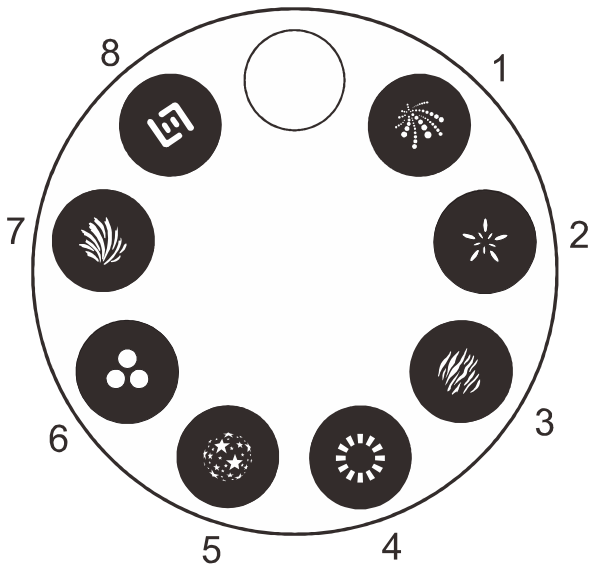

Rotating gobo wheel

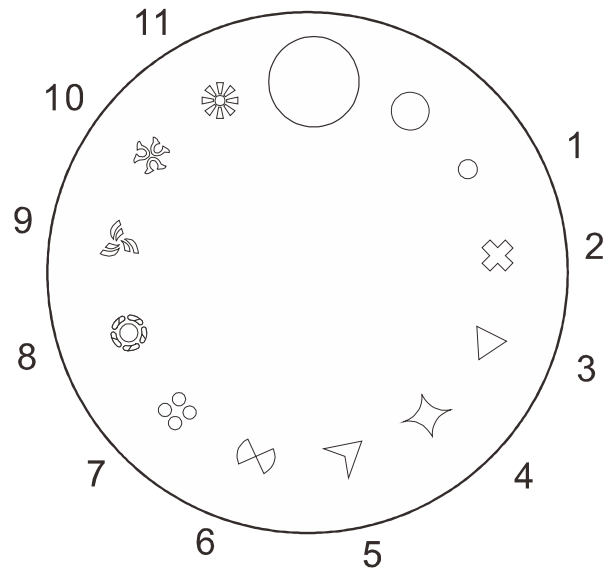

Fixed gobo wheel

## Colors

- 1 color wheels: 11 colors + open, split color, CW/CCW rotation, variable speed

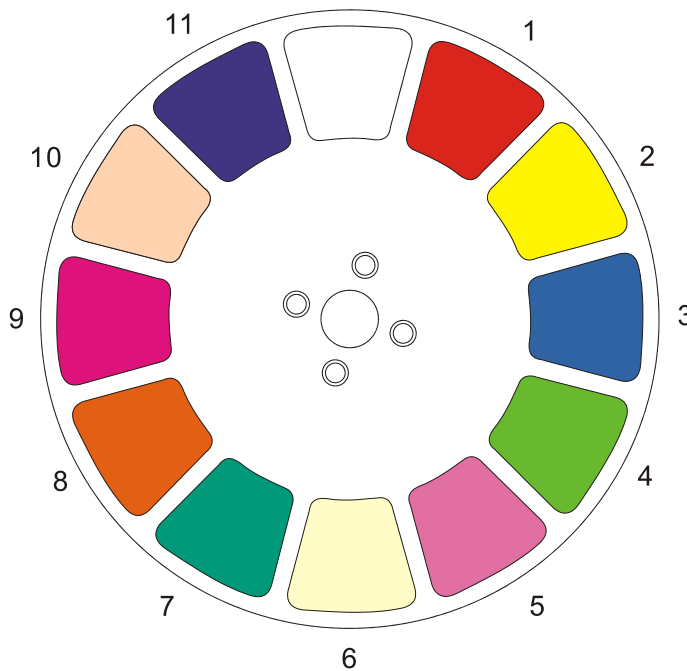

- Color 1: red
- Color 2: yellow
- Color 3: blue
- Color 4: light green
- Color 5: pink
- Color 6: light yellow
- Color 7: green
- Color 8: orange
- Color 9: magenta
- Color 10: CTO
- Color 11: UV

Menu structure

350 BSW – Menu Structure				
Revision: A			Valid from firmware version: 1.0	
Level 1	Level 2	Level 3	Level 4	Info
Run setting	Address Setting Value Display Slave Address Auto-Program Music Program	Address: 001~ XXX Auto Program....., All, Off Slave 1,2,3 Master /Slave Master/ Slave		Setting the DMX address Display the channel value Choose the slave address Run auto program in master or slave Run music program in master or slave
Device Info	Time Info	Since power on Total Time Last Time Lamp On Time Lamp Off Time Last Time Code Clear Last Time Lamp Time Code Clear Lamp Time	XXXXXX Hour XXXXXX Hour XXXXXX Hour XXXXXX Hour XXXXXX Minute Password: XXX(88) Yes/No Password: XXX(111) Yes/No	Since power on time Product total run time Last product run time Lamp on time Lamp close time Clear last time password Clear last time Clear lamp time password Clear lamp time
	Temperature	Body Temperature	XXX °C/°F	Body temperature
	Software Version	X.X		The software version
Lamp Control	Lamp On/Off Power On Lamp On Console Lamp On Console Lamp Off Lamp On Temp. Lamp Off Temp.	On/Off Enable/Disable Enable/Disable Enable/Disable 20~79, 45°C /68~174 , 113°F 80~139, 130°C/176~282,266°F		Open lamp Power on open lamp Console open lamp Console close lamp Open lamp below temperature Close lamp above temperature
System Setting	Status Setting	Console Set Addr No Signal Status Pan Reverse Tilt Reverse Pan Scan Degree Scan Feedback Scan Speed Mic. Sensitivity Standby Time	Enable /Disable Off/Hold/Auto/Music Enable/Disable Enable/Disable 360/540 Enable/Disable Quick/Middle/Low/Slow 0~99% Disable/1~20~99 Min	Address can be changed by console The status while no signal Pan Reverse Tilt Reverse Pan Scan Degree Scan Feedback Change the scan speed Microphone sensitivity Standby time
	Fan Speed	Smart Control High Speed Low Speed		Auto fans speed Fans high speed Fans low speed
	Display Setting	Backlight Time Key Lock Language	1~80 Min/Disable Enable/Disable Chinese/English	Backlight off time Press <menu> 3s to unlock Change the language

	Temperature Unit	Celsius Fahrenheit		Temperature unit
	Value Default	Auto Program ,Pan.....	Auto Program =XXX	The default value
	Wireless Dev	Wireless Off Wireless On Wireless Trans. Wireless Reset		Wireless off Wireless on Wireless transfer DMX data to another Wireless reset
	Restore Default	Restore/Cancel		Restore to default value
Reset	System Reset Scan Reset Color Reset Gobo Reset Strobe Reset Others Reset			System reset Pan an tilt motor reset All color motor reset All gobo motor reset All strobe motor reset All other motor reset
Channel Adjust	Test Mode	Auto Program.....		Every channel test
	Manual Mode	Auto Program :	Auto Program =XXX :	Manual control
	Adjust Mode	Input Password Pan :	Password=XXX(99) Pan=XXX :	The password of adjust mode Fixed all begin position
Channel Setting	Channel Mode	Standard Mode Basic Mode Extended Mode Custom Mode 1 Custom Mode 2 Custom Mode 3		Standard channel mode Basic channel mode Extended channel mode Custom channel mode 1 Custom channel mode 2 Custom channel mode 3
	Set Custom Mode1 Set Custom Mode2 Set Custom Mode3	Max Channel Auto Program :	Channel = XX Auto Program= CH xx :	Change the channel order
Program Edit	Select Prog.	Program Unit 1 Program Unit 2 Program Unit 3	Program 1 ~10 Program 1 ~ 10 Program 1 ~ 10	Choose build-in program for slave 1 Choose build-in program for slave 2 Choose build-in program for slave 3
	Program Edit	Auto-Program1 : Auto-Program10	Run Step 1=Scene xxx Step 10=Scene xxx	Choose the scene for program 1 : Choose the scene for program 10
	Scene Edit	Scene Edit:001-250	Pan,.....Pan=xxx Scene Time =xxx Input By Console	Edit the channel DMX Edit the scene time Get scene DMX form console
	Record Scene	Scene XX->XX		Record scene form console

## ⚠Notes

Settings highlighted in light grey are default values.

Level 1	Level 2	Level 3	Level 4	Info
System Setting	Status Setting	Console Set Addr No Signal Status Pan Reverse Tilt Reverse Pan Scan Degree Scan Feedback Scan Speed Mic. Sensitivity Standby Time	Enable/Disable Off/Hold/Auto/Music Enable/Disable Enable/Disable 360/540 Enable/Disable Quick/Middle/Low/Slow 0~99% Disable/1~20~99 Min	Address can be changed by console The status while no signal Pan Reverse Tilt Reverse Pan Scan Degree Scan Feedback Change the scan speed Microphone sensitivity Standby time
	Fan Speed	Smart Control High Speed Low Speed		Auto fans speed Fans high speed Fans low speed
	Display Setting	Backlight Time Key Lock Language	1~80 Min/Disable Enable/Disable Chinese/English	Backlight off time Press <menu> 3s to unlock Change the language
	Temperature Unit	Celsius Fahrenheit		Temperature unit
	Value Default	Pan.....	Pan = XXX	The default value
	Wireless Dev	Wireless Off Wireless On Wireless Trans. Wireless Reset		Wireless off Wireless on Wireless transfer DMX data to another Wireless reset
	Restore Default	Restore/Cancel		Restore to default value
Reset	System Reset Scan Reset Color Reset Gobo Reset Strobe Reset Others Reset			System reset Pan an tilt motor reset All color motor reset All gobo motor reset All strobe motor reset All other motor reset
Channel Adjust	Test Mode	Pan.....		Every channel test
	Manual Mode	Pan :	Pan = XXX :	Manual control
	Adjust Mode	Input Password Pan :	Password = XXX(99) Pan = XXX :	The password of adjust mode Fixed all begin position

### Notes

Settings highlighted in light grey are default values.

Level 1	Level 2	Level 3	Level 4	Info
Channel Setting	Channel Mode	Standard Mode Basic Mode Extended Mode Custom Mode 1 Custom Mode 2 Custom Mode 3		Standard channel mode Basic channel mode Extended channel mode Custom channel mode 1 Custom channel mode 2 Custom channel mode 3
	Set Custom Mode1 Set Custom Mode2 Set Custom Mode3	Max Channel Pan :	Channel = XX Pan = CH01 :	Change the channel order
Program Edit	Select Prog.	Program Unit 1 Program Unit 2 Program Unit 3	Program 1 ~10 Program 1 ~ 10 Program 1 ~ 10	Choose build-in program for slave 1 Choose build-in program for slave 2 Choose build-in program for slave 3
	Program Edit	Auto-Program1 : Auto-Program10	Run Step 1 = Scene xxx Step 8 = Scene xxx	Choose the scene for program 1 : Choose the scene for program 10
	Scene Edit	Scene Edit: 001-250	Pan,.....Pan = xxx Scene Time = xxx Input By Console	Edit the channel DMX Edit the scene time Get scene DMX form console
	Record Scene	Scene XX->XX		Record scene form console

 **Notes**

Settings highlighted in light grey are default values.

DMX protocol

350 BSW - DMX Protocol									
Revision: A					Valid from firmware version: 1.0				
DMX mode			Name	DMX value		DMX percentage		Function	Default DMX Value
Standard (19ch)	Basic (16ch)	Extended (22ch)							
1	1	1	Strobe/Shutter	0	31	0.0 %	12.2 %	Closed	0(0%)
				32	63	12.5 %	24.7 %	Open	
				64	127	25.1 %	49.8 %	Synchronous strobe from slow to fast	
				128	159	50.2 %	62.4 %	Open	
				160	223	62.7 %	87.5 %	Random strobe from slow to fast	
				224	255	87.8 %	100.0 %	Open	
2	2	2	Intensity	0	255	0.0 %	100.0 %	No light → Full light	0(0%)
		3		0	65535	0.0 %	100.0 %	Intensity fade, fine (LSB)	
3	3	4	Color wheel	0	17	0.0 %	6.7 %	Open	0(0%)
				18	27	7.1 %	10.6 %	Color 1	
				28	37	11.0 %	14.5 %	Color 2	
				38	47	14.9 %	18.4 %	Color 3	
				48	57	18.8 %	22.4 %	Color 4	
				58	67	22.7 %	26.3 %	Color 5	
				68	77	26.7 %	30.2 %	Color 6	
				78	87	30.6 %	34.1 %	Color 7	
				88	97	34.5 %	38.0 %	Color 8	
				98	107	38.4 %	42.0 %	Color 9	
				108	117	42.4 %	45.9 %	Color 10	
				118	127	46.3 %	49.8 %	Color 11	
				128	187	50.2 %	73.3 %	Color1 continuous rotation CW from fast to slow	
				18	195	73.3 %	76.5 %	Stop	

				8		7%	%	
				196	255	76.9%	100.0%	Color1 continous rotation CCW from slow to fast
4	4	5	Gobo wheel (static)	0	7	0.0%	2.7%	Open gobo
				8	10	3.1%	3.9%	Gobo 1
				11	13	4.3%	5.1%	Gobo 2
				14	16	5.5%	6.3%	Gobo 3
				17	19	6.7%	7.5%	Gobo 4
				20	22	7.8%	8.6%	Gobo 5
				23	25	9.0%	9.8%	Gobo 6
				26	28	10.2%	11.0%	Gobo 7
				29	31	11.4%	12.2%	Gobo 8
				32	34	12.5%	13.3%	Gobo 9
				35	37	13.7%	14.5%	Gobo 10
				38	40	14.9%	15.7%	Gobo 11
				41	43	16.1%	16.9%	Open gobo
				44	50	17.3%	19.6%	Gobo 1 shake
				51	57	20.0%	22.4%	Gobo 2 shake
				58	64	22.7%	25.1%	Gobo 3 shake
				65	71	25.5%	27.8%	Gobo 4 shake
				72	78	28.2%	30.6%	Gobo 5 shake
				79	85	31.0%	33.3%	Gobo 6 shake
				86	92	33.7%	36.1%	Gobo 7 shake
93	99	36.5%	38.8%	Gobo 8 shake				
100	106	39.2%	41.6%	Gobo 9 shake				
107	113	42.0%	44.3%	Gobo 10 shake				
114	127	44.7%	49.8%	Gobo 11 shake				
								0(0%)

				12 8	187	50. 2%	73.3 %	Gobo wheel continous rotation CW from slow to fast	
				18 8	195	73. 7%	76.5 %	Stop	
				19 6	255	76. 9%	100. 0%	Gobo wheel continous rotation CCW from slow to fast	
5	5	6	Rotating gobo wheel	0	7	0.0 %	2.7%	Open gobo	0(0%)
				8	12	3.1 %	4.7%	Gobo 1	
				13	17	5.1 %	6.7%	Gobo 2	
				18	22	7.1 %	8.6%	Gobo 3	
				23	27	9.0 %	10.6 %	Gobo 4	
				28	32	11. 0%	12.5 %	Gobo 5	
				33	37	12. 9%	14.5 %	Gobo 6	
				38	42	14. 9%	16.5 %	Gobo 7	
				43	47	16. 9%	18.4 %	Gobo 8	
				48	57	18. 8%	22.4 %	Gobo 1 shake	
				58	67	22. 7%	26.3 %	Gobo 2 shake	
				68	77	26. 7%	30.2 %	Gobo 3 shake	
				78	87	30. 6%	34.1 %	Gobo 4 shake	
				88	97	34. 5%	38.0 %	Gobo 5 shake	
				98	107	38. 4%	42.0 %	Gobo 6 shake	
				10 8	117	42. 4%	45.9 %	Gobo 7 shake	
				11 8	127	46. 3%	49.8 %	Gobo 8 shake	
				12 8	187	50. 2%	73.3 %	Gobo wheel continous rotation CW from slow to fast	
				18 8	195	73. 7%	76.5 %	Stop	
				19 6	255	76. 9%	100. 0%	Gobo wheel continous rotation CCW from slow to fast	
6	6	7	Gobo rotating/posit ioning gobo wheel	0	127	0.0 %	49.8 %	Gobo rotation positioning	0(0%)
				12 8	187	50. 2%	73.3 %	Gobo continous rotation CW from slow to fast	
				18 8	195	73. 7%	76.5 %	Stop	

				19 6	255	76. 9%	100. 0%	Gobo continous rotation CCW from slow to fast	
7		8		0	655 35	0.0 %	100. 0%	Gobo rotation/positioning, fine (LSB)	
8	7	9	Focus	0	255	0.0 %	100. 0%	Near → Far	0(0%)
		10		0	655 35	0.0 %	100. 0%	Focus, fine (LSB)	
9	8	11	Zoom	0	255	0.0 %	100. 0%	Wide → Narrow	0(0%)
		12		0	655 35	0.0 %	100. 0%	Zoom, fine (LSB)	
10	9	13	Prism1	0	127	0.0 %	49.8 %	Off	0(0%)
				12 8	255	50. 2%	100. 0%	On	
11	10	14	Prism1 rotation	0	127	0.0 %	49.8 %	Prism indexed	0(0%)
				12 8	187	50. 2%	73.3 %	Prism continous rotation CW from slow to fast	
				18 8	195	73. 7%	76.5 %	Stop	
				19 6	255	76. 9%	100. 0%	Prism continous rotation CCW from slow to fast	
12	11	15	Prism2	0	127	0.0 %	49.8 %	Off	0(0%)
				12 8	255	50. 2%	100. 0%	On	
13	12	16	Frost	0	127	0.0 %	49.8 %	Off	0(0%)
				12 8	255	50. 2%	100. 0%	On	
14	13	17	Pan	0	255	0.0 %	100. 0%	Pan	0(0%)
14		18		0	655 35	0.0 %	100. 0%	Pan, fine (LSB)	
16	14	19	Tilt	0	255	0.0 %	100. 0%	Tilt	46(18.0%)
17		20		0	655 35	0.0 %	100. 0%	Tilt, fine (LSB)	
18	15	21	Scan speed	0	255	0.0 %	100. 0%	Scan speed from fast to slow	0(0%)
19	16	22	Special controls	0	9	0.0 %	3.5%	No function	0(0%)
				10	19	3.9 %	7.5%	Open light after 5 seconds	
				20	29	7.8 %	11.4 %	Close light after 5 seconds	
				30	39	11. 8%	15.3 %	Color wheel half color switch	
				40	49	15. 7%	19.2 %	Color wheel random positioning	

				50	59	19.6%	23.1%	Reserved
				60	69	23.5%	27.1%	Reset all motor after 5 seconds
				70	79	27.5%	31.0%	Scan motor reset after 5 seconds
				80	89	31.4%	34.9%	All color motor reset after 5 seconds
				90	99	35.3%	38.8%	All gobo motor reset after 5 seconds
				100	109	39.2%	42.7%	All strobe motor reset after 5 seconds
				110	119	43.1%	46.7%	Other motor reset after 5 seconds
				120	129	47.1%	50.6%	Built-in program 1
				130	139	51.0%	54.5%	Built-in program 2
				140	149	54.9%	58.4%	Built-in program 3
				150	159	58.8%	62.4%	Built-in program 4
				160	169	62.7%	66.3%	Built-in program 5
				170	179	66.7%	70.2%	Built-in program 6
				180	189	70.6%	74.1%	Built-in program 7
				190	199	74.5%	78.0%	Built-in program 8
				200	209	78.4%	82.0%	Built-in program 9
				210	219	82.4%	85.9%	Built-in program 10
				220	255	86.3%	100.0%	Reserved

 Notes

**Do not switch off the fixture within the first minute after switching on. Wait for at least 5 minutes to switch on the fixture.**

## Technical specification

### Optical

- Light source: Silver 350W
- Expected average lifetime: 1000 hours
- Beam angle (zoom): SPOT: 3°- 40° BEAM: 3°-15° WASH: 10°-60°
- Focus: Variable range, linear focus
- Prism: one 8-facet prism, one flat 8-facet prism, individually controllable, generating two rings of prisms rotating in opposite directions.
- Frost: variable frost system for a soft and natural field

### Photometric

- Total Output (Lumen): 11000 lumens
- Color temperature: 6500K

### Gobo

- Rotating gobo: 8 interchangeable gobos + open, indexing, CW/CCW rotation, variable speed
- Static gobo wheel: 11 gobos + open, CW/CCW rotation, variable speed
- Gobo outside diameter: 14.4mm
- Max. Image diameter: 7.0mm
- Max. Thickness: 0.3mm(Metal)
- Glass/Metal gobo: Metal

### Color

Color wheel: 11 colors + open, split color, CW/CCW rotation, variable speed

### Electrical

- Power input, nominal: AC 100-240V, 50/60Hz
- Max. Power consumption: 550W, max current: 5.5A, PF: 0.96
- Power supply unit: Auto-ranging electronic SMPS
- Main fuse: 250V/6.3A
- Ballast: SVD H350

### Control and programming

- Control channels (DMX): 19/16/22
- Protocol: DMX-512
- Display: Graphic LCD backlit

### Physical / Installation

- Weight: 24 kg (53 lbs.)
- IP rating: IP20
- Material: Aluminum, steel, plastic

- Mounting points: Four quarter-turn locking points + attachment points for safety wire

### Dynamic effects

- Pan/Tilt movement: 540°/270°, 8 or 16 bit control
- Strobe: 1-20Hz, synchronized, pulse effects
- Dimmer: 0-100%, 16-bit, mechanical dimming

### Thermal

- Operating range: 14°F to 113°F (-10°C to +45°C)
- Startup range: 5°F to 113°F (-15°C to +45°C)
- Storage range: -40°F to 140°F (-40°C to +60°C)
- Cooling: Active fan
- Humidity: ≤85%

### Connections

- AC power: Neutrik powerCon
- DMX data input/output: Chassis 5-pin (3-pin optional) Neutrik XLR (in/out)

### Certification and Safety

- EMC: EN 55103-1:2009, EN 55103-2:2009, EN 61000-3-2:2006+A2:2009, EN 61000-3-3:2013
- Safety: EN 60598-2-17:1989/A2:1991

### Photometric

#### TD-350 BSW(SPOT)

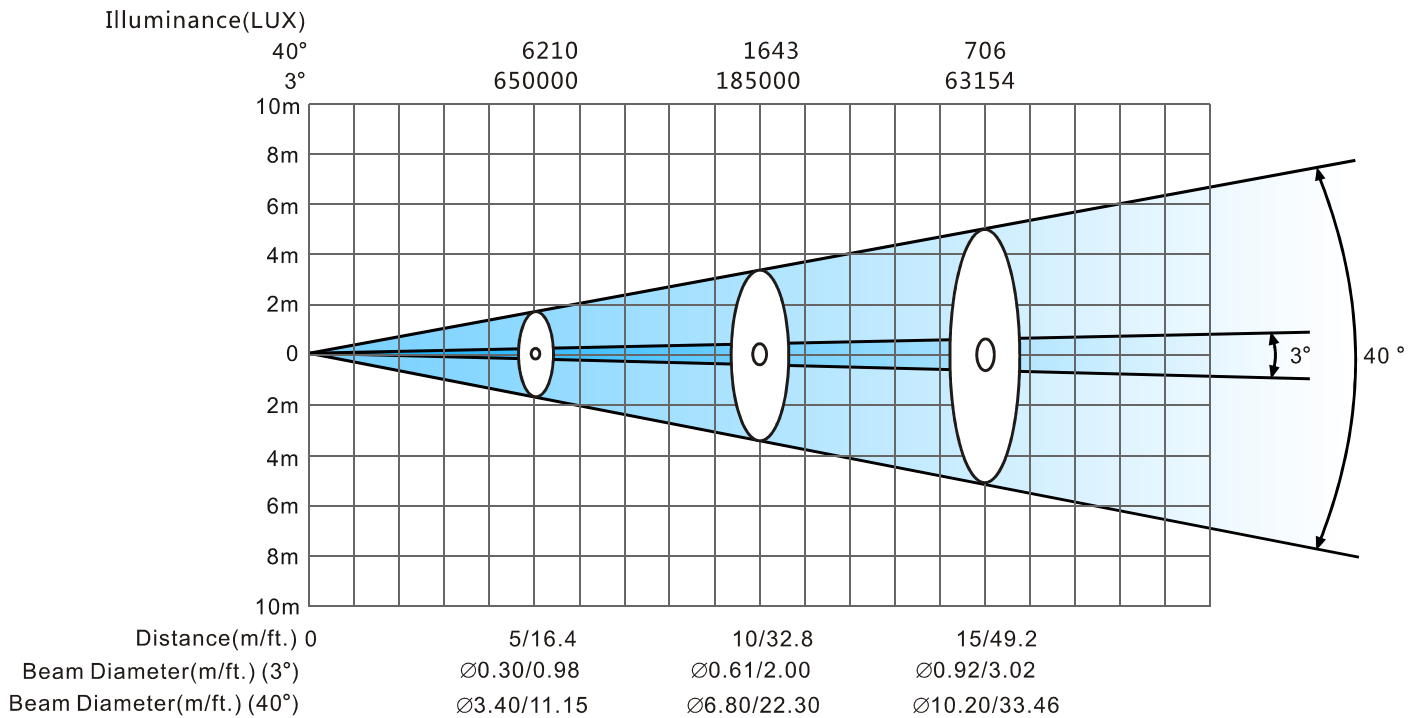

## TD-350 BSW(BEAM)

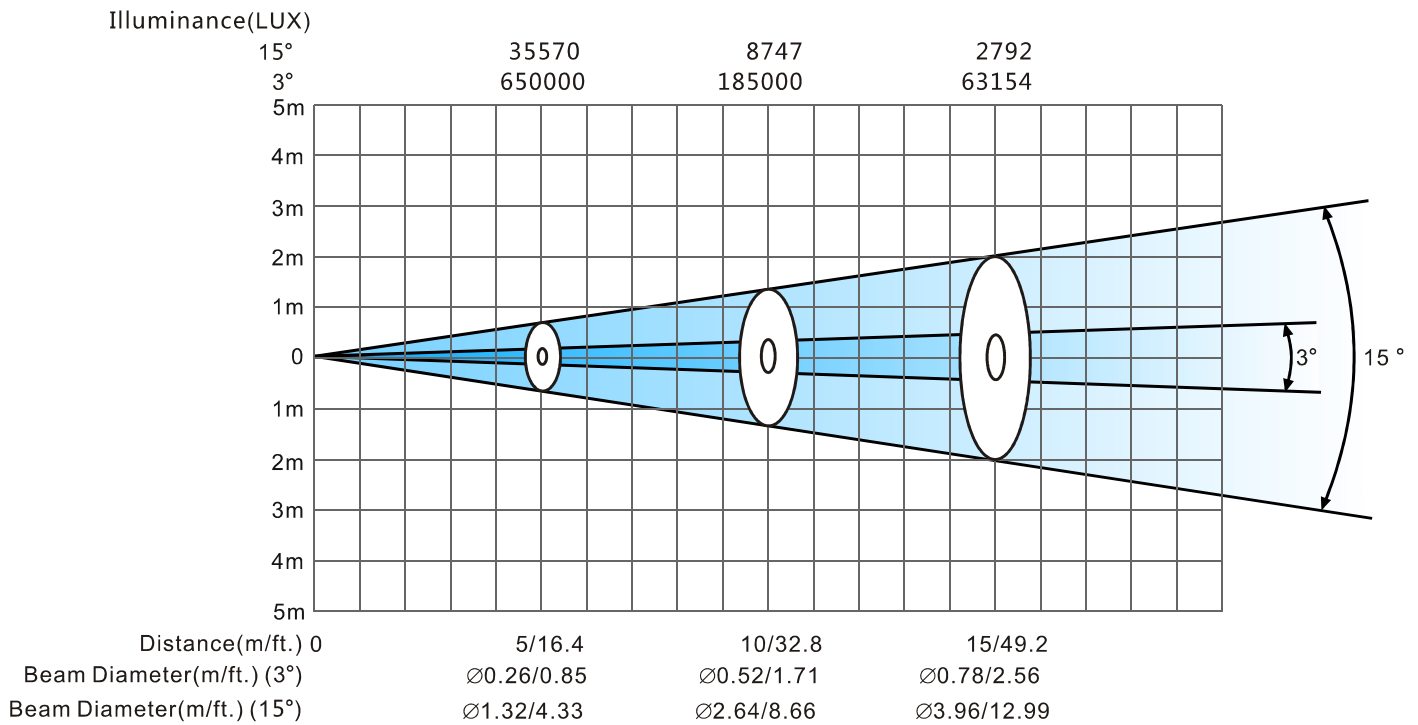

## TD-350 BSW(WASH)

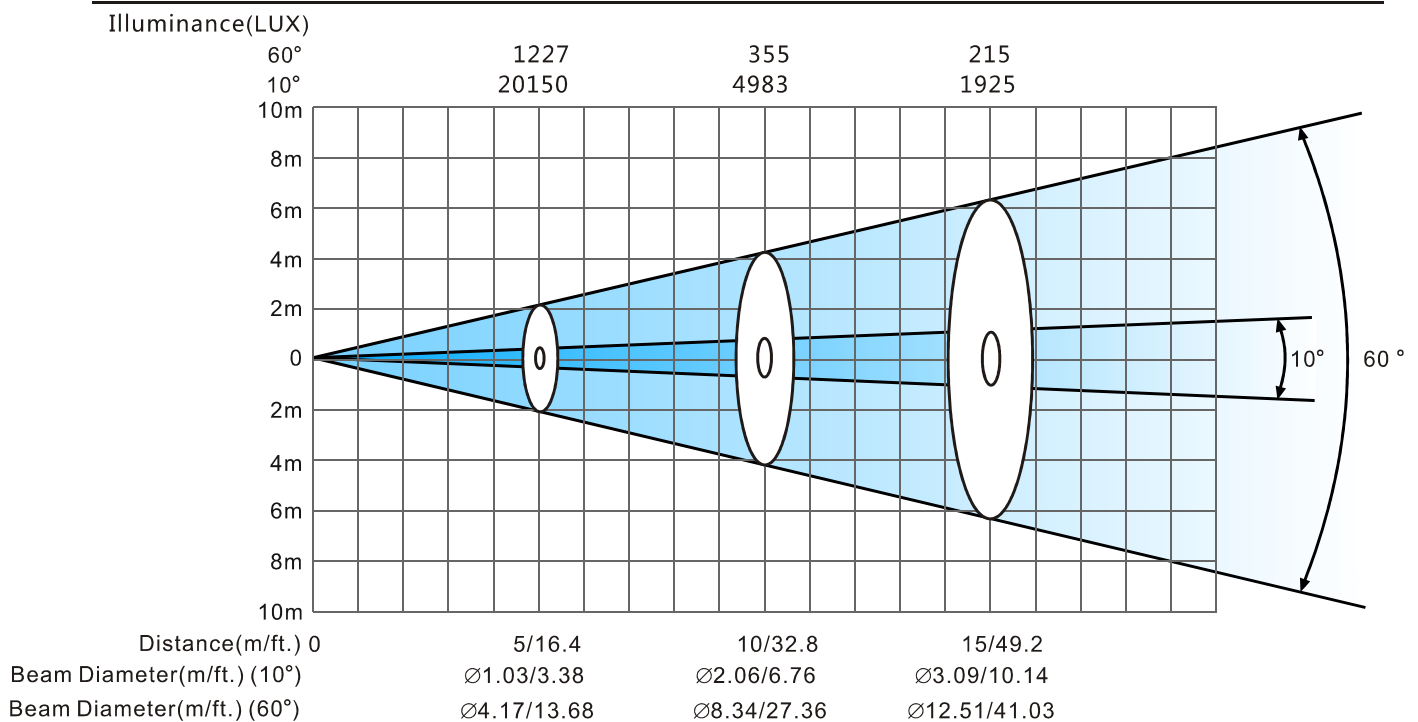

### Other features

- Eco-friendly design: equipped with intelligent tracking system to decrease the power of lamp source.
- Power setting: built-in continuous rechargeable battery, allowing setting functional data via LCD interface without power connection
- Sleep mode: uses the most advanced technology to remotely activate sleep mode. When the lamp is disconnected from signal, the sleep mode is enabled automatically to make it more stable and safer. Sleep time can be

customized.

- Communication design: DMX wired or wireless signal transmission.

## Cleaning and maintenance

It is required that the fixture should be kept clean and well maintained to ensure its reliability. Its lifespan mainly depends on the working environment and proper operation. Should you have any questions, please consult a technical engineer of GTD Lighting.

### Notes

Damage resulted from dust, smoke, oil or improper use is not covered by warranty.

### Warning

Disconnect the fixture from AC power, and let it cool down for at least 15 minutes before opening the housing. Make sure to use a soft cloth to clean the optical components, and be careful, as the coating is easily scratched. Do not use any organic solvent such as alcohol to clean the reflector mirror, dichroic color filters or housing of the fixture.

- If the lens is cracked or otherwise damaged, replace it immediately.
- If the lamp becomes damaged or deformed in any way it must be replaced.
- If the light from the lamp appears dim, this normally indicates that it is reaching the end of its life span and should be changed at once. Aged lamps run to the extremity of their life might explode.
- If fixture does not function, check the fuse on the power socket of the fixture. Replace the fuse of the same specification if it is blown.
- The fixture is equipped with thermal-protection device that will switch off the lamp in case of overheating. If this happens, please check that the fans are not blocked, and clean them if they are dirty. Check whether the fans are operational. If not, call a qualified technician. Troubleshoot and correct the problem before switching on the fixture again. Any maintenance work should only be carried out by qualified technicians.
- To ensure the continuous rotation of the rotating gobos and linear motion of the focus lens, it is recommended that the bearings on the rotating gobos and the 2 shafts for the focus system are lubricated periodically, preferably every 3-6 months. Use only high quality, high-temperature resistant grease. When lubricating the bearings, a syringe with a fine needle is the best way to grease the bearings around each gobo. Be aware not to use too much grease, and stain the parts around.

Troubleshooting

Problem	Possible Cause	Suggested Correction
No response after connected to A/C power	Power switch not turned on.	Turn on power switch.
	Take out the fuse and check if it is blown.	Locate the blown fuse. Remove the broken fuse. Insert a replacement fuse of the correct amperage.
	Abnormal A/C input (A/C power socket, power cables, luminaire power socket).	Replace AC power socket and power cables, and then adjust power socket for proper connection.
	No DC voltage from switching power supply.	Check if the switching power supply has DC voltage output. Replace the switching power supply.
No response or wrong response to the commands of the control system	DMX cables disconnected from fixture's DATA IN connector.	Connect DMX cable to the fixture's DATA IN connector.
	Open circuit or short circuit fault in the DMX cables.	Replace DMX cables as required.
	Wrong DMX address for the fixture in the control system.	Ensure the address in "Run setting > Address Setting > Address" of the fixture is consistent with the address in the control system.
	Misuse in "Channel setting > Channel Mode" of the fixture.	Choose the channel mode in "Channel setting > Channel Mode" of the fixture as required by the user.
The lamp does not start when switch is turned on	Malfunctioning of DMX cannon input/output connectors. No input/output voltage to the main control board of the fixture.	Troubleshooting the DMX XLR signal plate of the fixture, replace the main control board of the fixture.
	Normal end of lamp life.	Test the lamp in an adjacent fixture which is known to be operating properly and then replace as necessary.
	Shorted leads between ballast and the lamp.	Replace components as required.
The lamp is off unexpected	Incorrect ballast output.	Check ballast output to determine if it conforms to lamp requirements. If voltage and current do not stabilize in five to ten minutes warm-up time, ballast output is incorrect and adjustment should be made. Check capacitor wiring, if visibly available, to determine if capacitors are properly wired.
	The fixture is in sleep mode.	Should the fixture is not in active use for "standby time", the sleep mode is enabled automatically to make it more stable and safer, sleep time can be customized.
	Lamp has been operating: cool down time insufficient.	Environmental conditions such as extreme temperatures will have the fixture stop working, the lamps will require a period of time to cool and re-establish optimum starting conditions. Restart time varies with the degree of ventilation built into it, ambient temperature, and draft conditions.
Shaking, wrong position, and out of control gobo wheel	Overheat ballast resulting in premature failure or damaged ballast.	The ballast incorporate internal automatic-resetting thermal protection, which deactivates the ballast should it overheat. Normal operation resumes once the ballast has cooled sufficiently. Burned-out or failing lamps, or high temperatures in or around the fixture, can cause the ballast to overheat, so we need solve the problem and replace components as required.
	No function the connector between gobo wheel motor and drive, loose, damaged, or broken cables connecting the gobo wheel and drive.	Reconnect the gobo wheel motor to the drive, and replace cables as required.
	The gobo wheel motor's drive IC on the PCB might be out of condition.	Replace the drive having the same software version as required.
	Dislocated magnetic tube and positioning magnet, or damaged magnetic tube.	Calibrate the position of the magnetic tube to the positioning magnet, and replace magnetic tube as required.
	Shaking motor, wrong rotation angle, losing step or damaged motor.	Replace the motor as required.

Problem	Possible Cause	Suggested Correction
Decreased brightness, uneven pattern projections	Normal end of lamp life.	Test the lamp in an adjacent fixture which is known to be operating properly and then replace as necessary.
	The midline of the lamp is not aligned with the center point of the effect assembly (consisting of the rotating gobo wheel, static gobo wheel, color wheel, strobe, prism, and frost), focus module, and object lens.	Reinstall the lamp. Adjust the lamp position until the midline of the lamp is aligned with the center point of the effect assemblies (consisting of the rotating gobo wheel, static gobo wheel, color wheel, strobe, prism, frost, the focus adjusting module, and the object lens).
	Excessive dusts or smudges on the effect assembly, focus module and objective lens.	Follow the instructions stated in this user manual to clean the effect assembly, focus module and objective lens.
	Damaged or deformed effect assembly, focus module or objective lens.	Replace the damaged or deformed components.
Wrong color	Normal end of lamp life.	Test the lamp in an adjacent fixture which is known to be operating properly and then replace as necessary.
	Excessive dusts or smudges on the rotating gobo wheel or color wheel.	Follow the instructions stated in this user manual to clean the rotating gobo wheel or color wheel.
	Rotating gobo wheel, color wheel with coating wearing off, damages or deformation.	Replace the worn-off, damaged or deformed rotating gobo wheel and color wheel.
Non-clear shape	Excessive dusts or smudges on the rotating gobo wheel or color wheel.	Follow the instructions stated in this user manual to clean the rotating gobo wheel or color wheel.
	Excessive dusts or smudges on the focus module or objective lens.	Follow the instructions stated in this user manual to clean the focus module or objective lens.
	Damaged or deformed focus module or objective lens.	Replace the damaged or deformed focus module or objective lens.

System wiring diagram

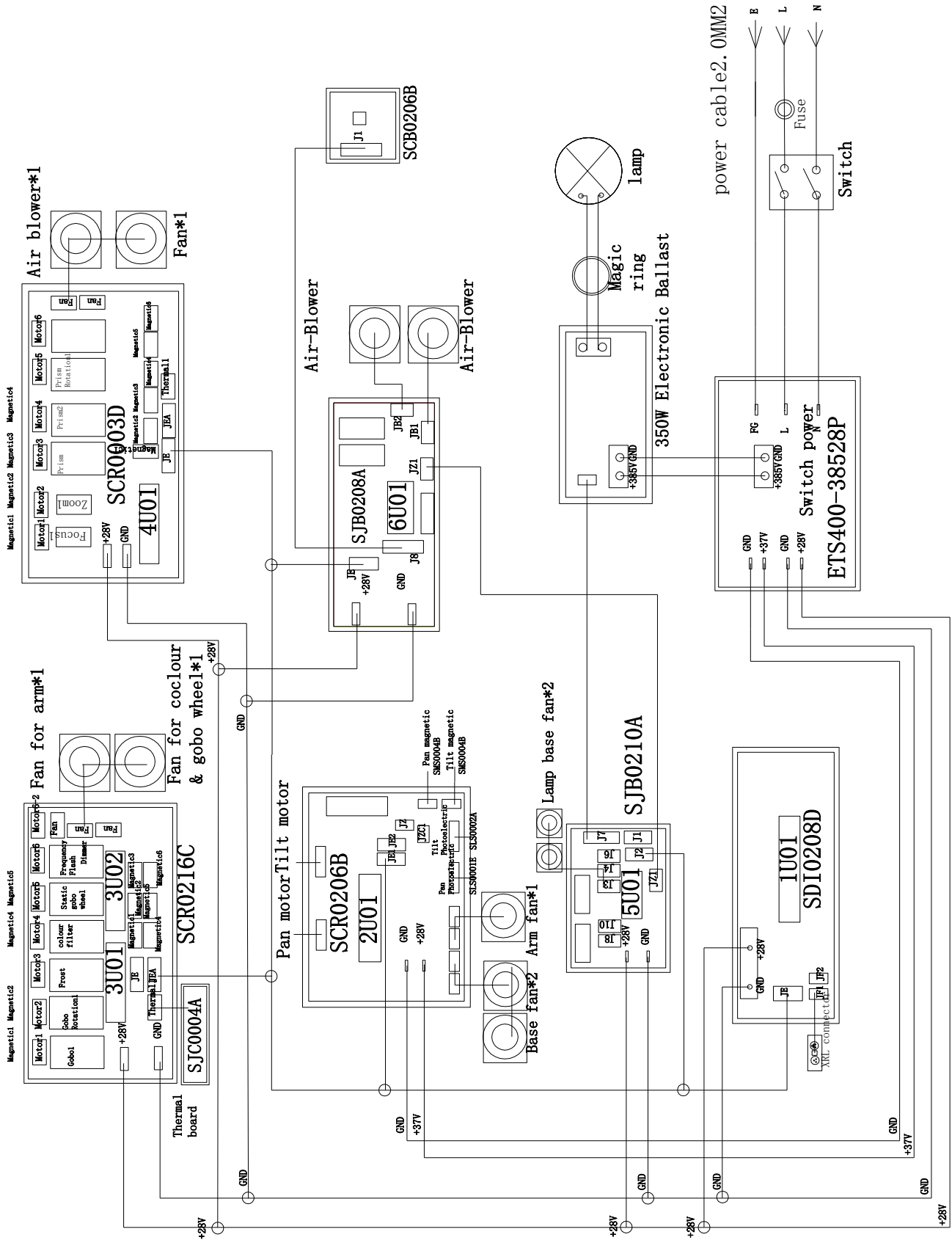

Spare parts list

Item	P/N	Qty	Notes
Switch power	1412050061B	1	EPFC400-3628N
Electronic Ballast	1412020016A	1	SVD H350 Philips
Lamp	1306030016A	1	Philips Silver 350W
Display plate	5809010326A	1	TD-350 BSW-101A21 SDI0208D-5/display plate 0208D-5
Scan plate	5809010327A	1	TD-350 BSW-201B21 SCR0206B/motor driver0206B
Fan Control Panel 0210A	5809010330A	1	TD-350 BSW-501B21 SJB0210A/ Fan Control Panel 0210A-2
Motor driver	5809010328A	1	TD-350 BSW-301B21&302C21 SCR0216C/motor driver 0216C-2
Motor driver	5809010329A	1	TD-350 BSW-401C21 SCR0003C/motor driver3C-7
Fan driver	5809010331A	1	TD-350 BSW-601H21 SJB0208A/fan driver 0208A-1
Transducer Adapter Plate 0206B-1	5801061003A	1	SCB0206B 12

Appendix 1

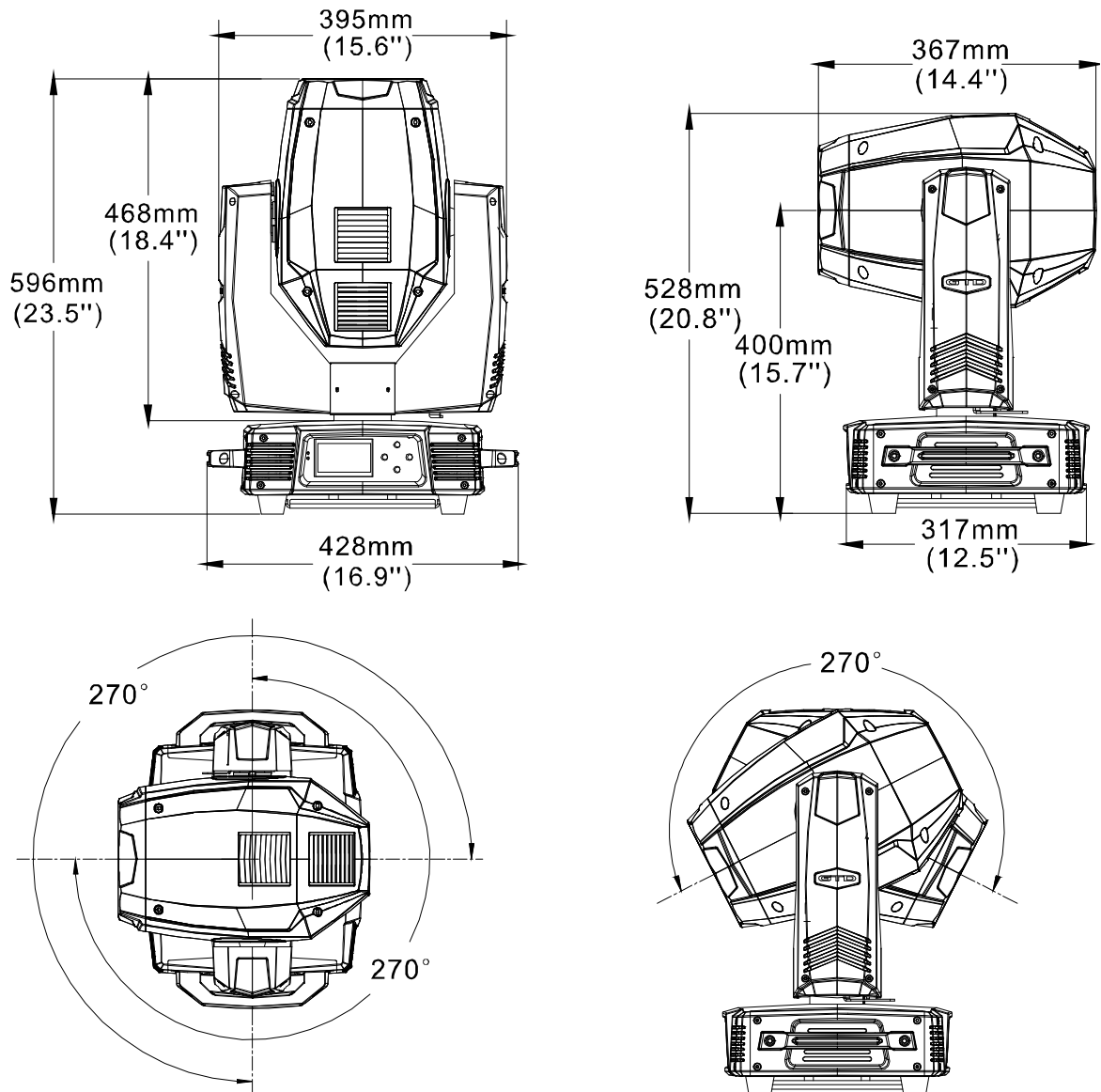

Notes: