

TUNGDOU

LED Moving Head

TD-LMZ 3019

User's Manual

Guangzhou GTD Lighting Technology Co., Ltd.

Tel: +86-20-61808296

Fax: +86-20-61812282

<http://www.gtd-lighting.com>







©2017 GTD all rights reserved. Information, specifications, diagrams, images, and instructions herein are subject to change without notice. GTD logo and identifying product names and numbers herein are trademarks of GTD. Copyright protection claimed includes all forms and matters of copyrightable materials and information now allowed by statutory or judicial law or hereinafter granted. Product names used in this document may be trademarks or registered trademarks of their respective companies and are hereby acknowledged. All non-GTD brands and product names are trademarks or registered trademarks of their respective companies.

GTD and all affiliated companies hereby disclaim any and all liabilities for property, equipment, building, and electrical damages, injuries to any persons, and direct or indirect economic loss associated with the use or reliance of any information contained within this document, and/or as a result of the improper, unsafe, insufficient and negligent assembly, installation, rigging, and operation of this product.

Contents

Safety instructions	4
General guidelines	5
Packing and shipping	6
Unpacking	6
Packing after use.....	6
Accessories	6
Product introduction	7
Installation	7
Clamps installation	7
Device installation	7
Power / Control connection	8
Power connection	8
Control connection	8
Testing	9
Control panel	9
Menu structure	10
DMX protocol	12
Technical specification	21
Cleaning and maintenance	20
Troubleshooting	22
System wiring diagram	23
Spare parts list	24
Appendix 1	24

Safety instructions

	<p>WARNING!</p> <p>Before using the fixture, read the latest version of the product user manual, paying particular attention to the safety instructions. Please check www.gtd-lighting.com for the latest revision/update of the user manual. The manufacture of this fixture, are not responsible for damages, resulting from misuse of this fixture, due to the disregard of the information printed in this user manual.</p>
	<p>DANGER!</p> <p>Hazardous voltage. Risk of lethal or severe electric shock.</p>
	<p>WARNING!</p> <p>Burn hazard. Hot surface. Do not touch.</p>
	<p>WARNING!</p> <p>Fire hazard.</p>
	<p>INDOORS USE ONLY!</p> <p>Do not expose fixture for rain and moisture.</p>
	<p>It's essential that the fixture is properly grounded. Only qualified personnel should perform electrical connections.</p>
	<p>WARNING!</p> <p>Wear protective eyewear. Never look directly into the light source.</p>

- Only qualified and certified personnel should perform installation of this fixture and only the original rigging parts (brackets) included with this fixture should be used for installation.
- Before applying power to the fixture, check that the source voltage matches the fixture's requirement. Every fixture must be earthed (grounded) and installed in accordance with local electricity regulations. Do not connect it to a dimmer system.
- Never look directly into the light source of this fixture to prevent risk of injury to your retina, which may induce blindness.

General guidelines

- Never open this fixture while in use.
- The fixture should be kept clean. **DO NOT** operate the fixture in extreme heat or dusty environments. Avoid contact with chemical liquid.
- This fixture is a professional light effect designed for **INDOOR / DRY LOCATIONS ONLY** on stage, in nightclubs, theatres, etc.
- **Minimum** distance to lighted objects must be **3.28feet (1m)**.
- **Maximum** temp of the external surface **158°F (70°C)**.
- **Maximum** ambient temperature **113°F (45°C)**.
- **Minimum** distance of inflammable materials from the surface **1.6 feet (0.5m)**.
- LED lamp should be changed if damaged or distorted in shape due to extreme heat.
- Cover, prism or LCD Menu Function Display with visible damages such as cracks or scratches must be replaced to ensure performance of the fixture.
- Disconnect the fixture from power before changing any parts or accessories.
- Make sure that the installation area can hold a minimum point load of 10 times the weight of all installed fixtures, clamps, cables, auxiliary equipment, etc. Check that the cover, clamps and locks are undamaged. Certified safety cables must always be used when installing the fixture.
- The fixture is only intended for installation, operation and maintenance by qualified professional. Instructions stated in the manual must be complied.
- The fixture must be kept in a well-ventilated place at least 50 cm away from any wall surface. Check if the fans or ventilation openings are unblocked.
- Broken or damaged cables can only be fixed or changed by certified technicians, certified local distributors or the manufacturer to ensure operational safety.
- Do not stick filters or other materials onto the lens. Do not modify the fixture or install other than GTD manufactured parts.
- For questions regarding safety operation, please contact our technical personnel or call the service hotline +8620 61808296.

Packing and shipping

Unpacking

Notes

All products are quality controlled and checked for any faults before they are dispatched to customers. If the fixture is damaged during delivery, the customer must notify the shipper and manufacturer to file a damage insurance claim. Photographic evidence of the damage must be provided.

Flight-Case

Open the cover of the flight-case and remove the plastic packing bags. Hold the handles of the fixture firmly and take it out carefully.

Cardboard box

Open the box and take out the whole set of packaging foam which contains both the fixture and its accessories. Remove the foam from the top, put away the accessories, and then take out the fixture wrapped in the plastic bag.

Packing after use

1. Switch off the fixture and wait for at least 5 minutes before disconnecting it from AC power. Cool down the fixture for at least 15 minutes before packing.
2. Flight case: Wrap the fixture in plastic bags. Hold it by the handles, and then carefully place it inside the flight case along with all the accessories. Close the cover. Do not upside down.
Cardboard box: Wrap the fixture in plastic bags. Put it in the packaging foam along with all the accessories. Place the other set of packaging foam on top then carefully put it inside the cardboard box.

Accessories

Item	Qty	Unit	Notes
User Manual	1	pc	
Clamp	1	set	G-clamp with 1/4-turn fasteners, for $\varnothing 42-52\text{mm}$, Max. 200 kg
safety cable	1	pc	$\varnothing 3*8\text{cm}$, with the hook , steel wire
Three-core waterproof power adapter-Female	1	pc	$0.5*2.5\text{mm}^2$, Rubber, IP67
Signal Line	1	set	5m

Notes

Accessories are subject to change without any prior written notice.

Product introduction

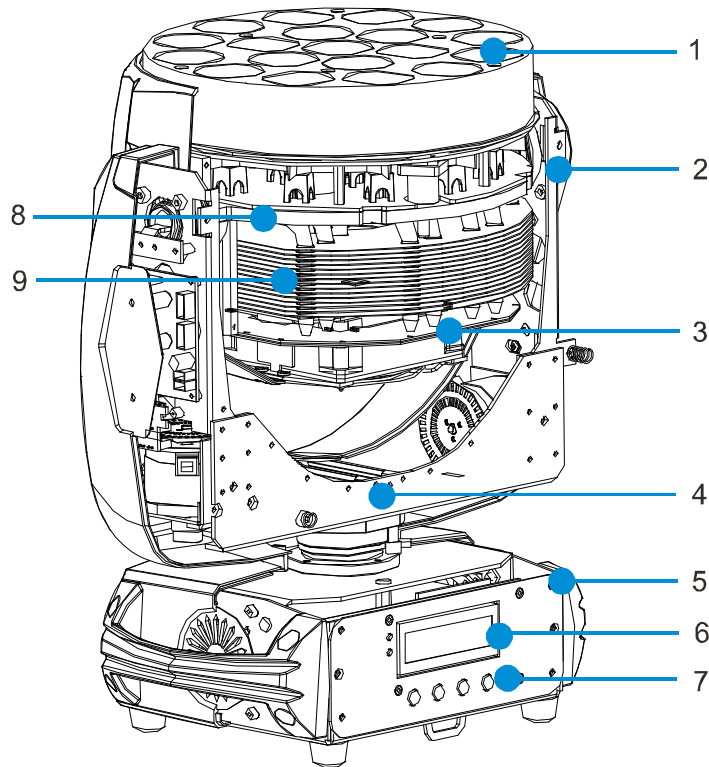

- | | | | | | |
|---|-------------------------------|---|------------------|---|--------------------|
| 1 | Lens | 2 | Tilt | 3 | Driver board |
| 4 | Pan | 5 | Base | 6 | LCD display screen |
| 7 | MENU, UP, DOWN, ENTER buttons | 8 | Copper substrate | 9 | Radiator |

Installation

Clamps installation

The fixture can be placed on the stage or mounted on the truss facing any direction. Attach the clamp to the mounting position on the base of the fixture.

Warning

Use one clamp when mounting the fixture. Turn the screws attached to the clamp to lock. Always remember to use the safety cable which goes through the mounting hole on the base. Do not attach the safety cable on the handle.

Device installation

1. Make sure there is no damage on the clamps or safety cables before installation.
2. The clamp is mounted on the base of the fixture. Horizontally insert the clamp into the mounting holes of the chassis. Fasten the clamp tightly.

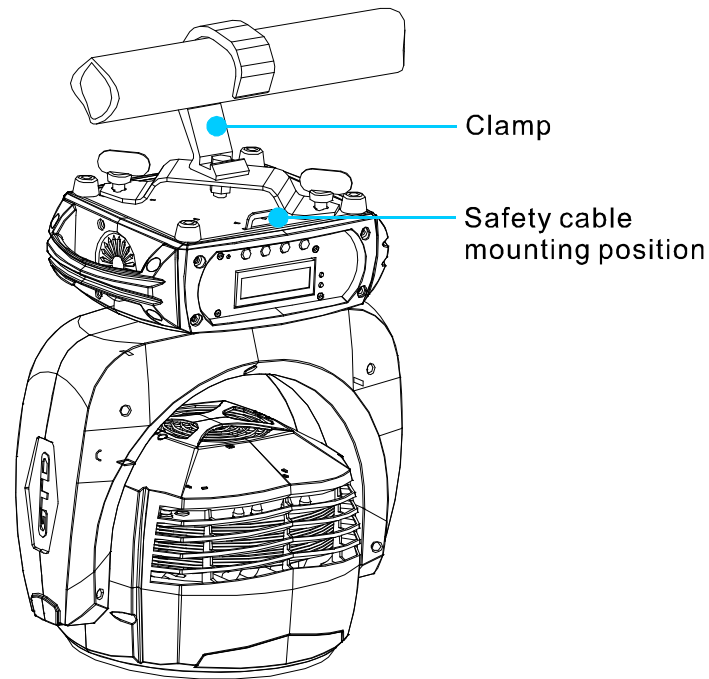

Power/ Control connection

Power connection

Connection method:

- L (Live) Brown wire
- E (Earth) Yellow / Green bi-color wire
- N (Neutral) Blue wire
- The voltage and frequency of the power source must be in compliance with the ones marked on the fixture. Please apply series connection when many sets of fixtures are connected to the power source to avoid heavy load to the power source. When the voltage is 100V, maximum 2 sets of fixtures could be allowed in each series connection. When the voltage is 240V, maximum 4 sets of fixtures could be allowed in each series connection. Another series connection should be set up for extra fixtures.

⚠Notes

It is essential that each fixture is correctly grounded and the electrical installation conforms to all relevant Standards / Codes of Practice for Safe Electrical Work.

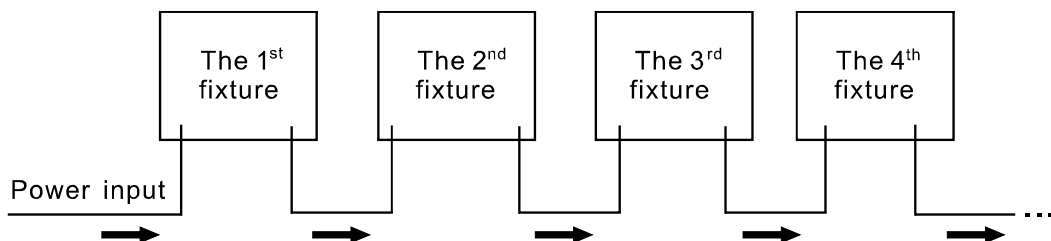

Control connection

The fixture has 5-pin XLR connectors for DMX data input and output (3-pin optional) as shown below. Connection between the console and fixture, and between fixtures must be made with 2 core screened DMX signal cable. Maximum connecting distance of signal cable is 150 meters. Additional DMX512 signal-amplifier are recommended for longer distance.

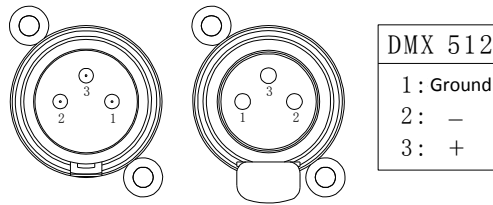

Connect the Console’s DMX OUTPUT to the first fixture’s DMX INPUT, then the first fixture’s DMX OUTPUT to the second fixture’s DMX INPUT and so on. It is recommended not to connect more than 32 units on a single DMX universe. On the last fixture’s output connect a DMX terminator. (The terminator is a XLR connector with a ¼ W and 120Ω resistor between the pin 2 and pin 3) as shown below:

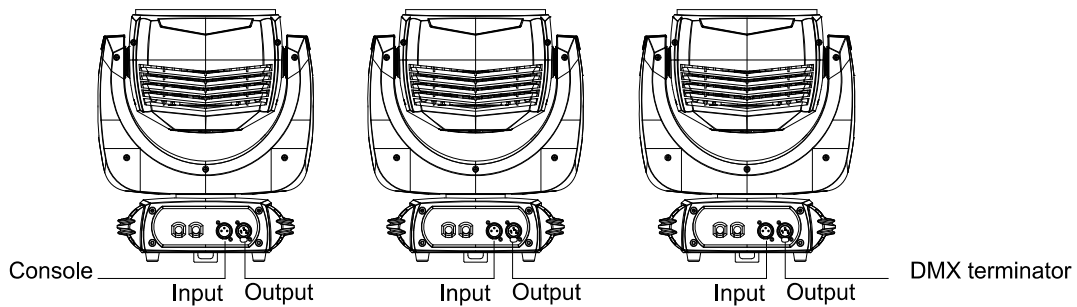

Testing

Connect the fixture to AC power. Check if the LED lamp is on and the fixture is independently controllable before putting into operation.

Control panel

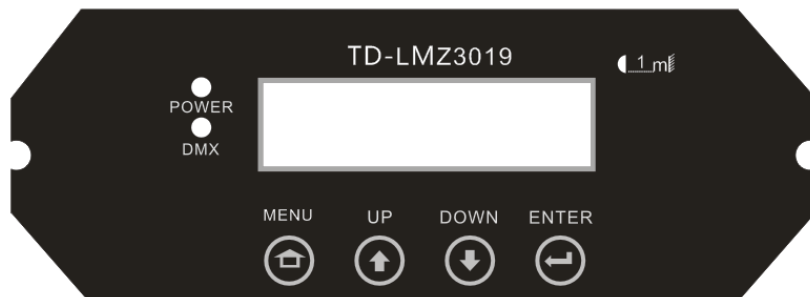

- The control panel features touch-sensitive buttons and LCD digital display for quick and easy setup of address code and functions menu.
- Press UP or DOWN to view or select the function menu.
- Press ENTER to choose a function and enter into corresponding sub menu. Each menu represents a specific function of the fixture.
- Press ENTER to select the specific function and save the changes or enter into the submenu, then press UP or DOWN to change the value of the selected function (increase or decrease).
- Press MENU to return to the previous menu or exit.
- LED indicators:
 - Power on: RED power LED indicator on
 - Signal on: Green DMX indicator on
 - No Signal: Green DMX indicator off

Menu structure

LMZ3019 – Menu Structure	
Revision: A	Valid from firmware version: 1.0

Level 1	Level 2	Level 3	Level 4	Info
Run setting	Address Setting Value Display Slave Address Auto-Program Music Program	Address: 001~XXX Pan, All, Off Slave1,2,3 Master /Slave Master/ Slave		Setting the DMX address Display the channel value Choose the slave address Run auto program in master or slave Run music program in master or slave
Device Info	Time Info	Since power on Total Time	XXXXXX Hour XXXXXX Hour	Since power on time Product total run time
	Temperature	Body Temperature	XXX °C/°F	Body temperature
	Software Version	X.X		The software version
System Setting	Status Setting	Console Set Addr No Signal Status Pan Reverse Tilt Reverse Pan Scan Degree Scan Feedback Scan Speed Mic. Sensitivity Standby Time	Enable/Disable Off/Hold/Auto/Music Enable/Disable Enable/Disable 630/540 Enable/Disable Quick/Middle/Low/Slow 0~99% Disable/1~20~99 Min	Address can be changed by console The status while no signal Pan Reverse Tilt Reverse Pan Scan Degree Scan Feedback Change the scan speed Microphone sensitivity Standby time
	Fan Speed	Smart Control High Speed Low Speed		Auto fans speed Fans high speed Fans low speed
	Display Setting	Backlight Time Key Lock Language	1~80 Min/Disable Enable/Disable Chinese/English	Backlight off time Press <menu> 3s to unlock Change the language
	Temperature Unit	Celsius Fahrenheit		Temperature unit
	Value Default	Pan.....	Pan =XXX	The default value
	Dimmer Mode	M0:...~M5:... M1		Dimmer mode select
	Restore Default	Restore/Cancel		Restore to default value
Reset	System Reset Scan Reset Zoom Reset			System reset Pan and tilt motor reset Zoom motor reset
Channel Adjust	Test Mode	Pan.....		Every channel test
	Manual Mode	Pan :	Pan =XXX :	Manual control
	Adjust Mode	Input Password Pan	Password=XXX(168) Pan=XXX	The password of adjust mode Fixed all begin position

		:	:	
Channel Setting	Channel Mode	Standard Mode Simplified Mode Extended Mode Custom Mode 1 Custom Mode 2 Custom Mode 3		Standard channel mode Simplified channel mode Extended channel mode Custom channel mode 1 Custom channel mode 2 Custom channel mode 3
	Set Custom Mode1 Set Custom Mode2 Set Custom Mode3	Max Channel Pan :	Channel = XX Pan = CH01 :	Change the channel order
Program Edit	Select Prog.	Program Unit 1 Program Unit 2 Program Unit 3	Program 1 ~10 Program 1 ~ 10 Program 1 ~ 10	Choose build-in program for slave 1 Choose build-in program for slave 2 Choose build-in program for slave 3
	Program Edit	Auto-Program1 : Auto-Program10	Run Step 1=Scene xxx Step 8=Scene xxx	Choose the scene for program 1 : Choose the scene for program 10
	Scene Edit	Scene Edit:001-250	Pan,.....Pan=xxx Scene Time=xxx Input By Console	Edit the channel DMX Edit the scene time Get scene DMX form console
	Record Scene	Scene XX->XX		Record scene form console

 Notes

Settings highlighted in light grey are default values

DMX protocol

LMZ3019 - DMX Protocol	
Revision: A	Valid from firmware version: 1.0

DMX protocol - Standard [22 channels]

DMX mode	Name	DMX value		DMX percentage		Function	Default DMX Value
Standard (22ch)							
1	Strobe/Shutter	0	31	0.0%	12.2%	Closed	0(0%)
		32	63	12.5%	24.7%	Open	
		64	127	25.1%	49.8%	Synchronous strobe from slow to fast	
		128	159	50.2%	62.4%	Open	
		160	223	62.7%	87.5%	Random strobe from slow to fast	
		224	255	87.8%	100.0%	Open	
2	Intensity	0	255	0.0%	100.0%	No light → Full light	0(0%)
		0	65535	0.0%	100.0%	Intensity fade, fine (LSB)	
3	Red 1	0	255	0.0%	100.0%	No light → Full light	0(0%)
		0	65535	0.0%	100.0%	Intensity fade, fine (LSB)	
4	Green 1	0	255	0.0%	100.0%	No light → Full light	0(0%)
		0	65535	0.0%	100.0%	Intensity fade, fine (LSB)	
5	Blue 1	0	255	0.0%	100.0%	No light → Full light	0(0%)
		0	65535	0.0%	100.0%	Intensity fade, fine (LSB)	
6	Whit 1	0	255	0.0%	100.0%	No light → Full light	0(0%)
		0	65535	0.0%	100.0%	Intensity fade, fine (LSB)	
7	Red 2	0	255	0.0%	100.0%	No light → Full light	0(0%)
		0	65535	0.0%	100.0%	Intensity fade, fine (LSB)	
8	Green 2	0	255	0.0%	100.0%	No light → Full light	0(0%)
		0	65535	0.0%	100.0%	Intensity fade, fine (LSB)	
9	Blue 2	0	255	0.0%	100.0%	No light → Full light	0(0%)
		0	65535	0.0%	100.0%	Intensity fade, fine (LSB)	
10	Whit 2	0	255	0.0%	100.0%	No light → Full light	0(0%)
		0	65535	0.0%	100.0%	Intensity fade, fine (LSB)	
11	Red 3	0	255	0.0%	100.0%	No light → Full light	0(0%)
		0	65535	0.0%	100.0%	Intensity fade, fine (LSB)	
12	Green 3	0	255	0.0%	100.0%	No light → Full light	0(0%)
		0	65535	0.0%	100.0%	Intensity fade, fine (LSB)	
13	Blue 3	0	255	0.0%	100.0%	No light → Full light	0(0%)
		0	65535	0.0%	100.0%	Intensity fade, fine (LSB)	
14	Whit 3	0	255	0.0%	100.0%	No light → Full light	0(0%)
		0	65535	0.0%	100.0%	Intensity fade, fine (LSB)	

15	Rainbow Function	0	9	0.0%	3.5%	No function	0(0%)
		10	39	3.9%	15.3%	Rainbow scene 1	
		40	71	15.7%	27.8%	Rainbow scene 2	
		72	103	28.2%	40.4%	Rainbow scene 3	
		104	135	40.8%	52.9%	Rainbow scene 4	
		136	167	53.3%	65.5%	Rainbow scene 5	
		168	199	65.9%	78.0%	Rainbow scene 6	
		200	231	78.4%	90.6%	Rainbow scene 7	
		232	255	91.0%	100.0%	Rainbow flow from slow to fast	
16	Color temperature	0	24	0.0%	9.4%	No function	0(0%)
		25	35	9.8%	13.7%	3200K	
		36	46	14.1%	18.0%	3400K	
		47	57	18.4%	22.4%	3600K	
		58	68	22.7%	26.7%	3800K	
		69	79	27.1%	31.0%	4000K	
		80	90	31.4%	35.3%	4200K	
		91	101	35.7%	39.6%	4400K	
		102	112	40.0%	43.9%	4600K	
		113	123	44.3%	48.2%	4800K	
		124	134	48.6%	52.5%	5000K	
		135	145	52.9%	56.9%	5200K	
		146	156	57.3%	61.2%	5400K	
		157	167	61.6%	65.5%	5600K	
		168	178	65.9%	69.8%	5800K	
		179	189	70.2%	74.1%	6000K	
		190	200	74.5%	78.4%	6200K	
		201	211	78.8%	82.7%	6400K	
		212	222	83.1%	87.1%	6600K	
223	233	87.5%	91.4%	6800K			
234	244	91.8%	95.7%	7000K			
245	255	96.1%	100.0%	7200K			
17	Zoom	0	255	0.0%	100.0%	Near → Far	0(0%)
		0	65535	0.0%	100.0%	Zoom, fine (LSB)	
18	Pan	0	255	0.0%	100.0%	Pan	0(0%)
		0	65535	0.0%	100.0%	Pan, fine (LSB)	
19	Tilt	0	255	0.0%	100.0%	Tilt	46(18.0%)
		0	65535	0.0%	100.0%	Tilt, fine (LSB)	
20	Scan speed	0	255	0.0%	100.0%	Scan speed from fast to slow	0(0%)
21	Dimmer Mode	0	5	0.0%	2.0%	M0:600Hz,Gama1.5,Smoth	0(0%)
		6	11	2.4%	4.3%	M1:600Hz,Gama1.5,Snap	

		12	17	4.7%	6.7%	M2:1200Hz,Gama1.5,Smoth	
		18	23	7.1%	9.0%	M3:1200Hz,Gama1.5,Snap	
		24	29	9.4%	11.4%	M4:600Hz,Gama2.0,Smoth	
		30	35	11.8%	13.7%	M5:600Hz,Gama2.0,Snap	
		36	255	14.1%	100.0%	Reserved	
22	Special controls	0	59	0.0%	23.1%	No function	0(0%)
		60	69	23.5%	27.1%	Reset all motor after 5 seconds	
		70	79	27.5%	31.0%	Scan motor reset after 5 seconds	
		80	89	31.4%	34.9%	Zoom motor reset after 5 seconds	
		90	119	35.3%	46.7%	No function	
		120	129	47.1%	50.6%	Built-in program 1	
		130	139	51.0%	54.5%	Built-in program 2	
		140	149	54.9%	58.4%	Built-in program 3	
		150	159	58.8%	62.4%	Built-in program 4	
		160	169	62.7%	66.3%	Built-in program 5	
		170	179	66.7%	70.2%	Built-in program 6	
		180	189	70.6%	74.1%	Built-in program 7	
		190	199	74.5%	78.0%	Built-in program 8	
		200	209	78.4%	82.0%	Built-in program 9	
		210	219	82.4%	85.9%	Built-in program 10	
220	239	86.3%	93.7%	No function			
240	249	94.1%	97.6%	Dimmer mode set			
250	255	98.0%	100.0%	No function			

DMX protocol - Simplified [22channels]

DMX mode	Name	DMX value		DMX percentage		Function	Default DMX Value
Basic (22ch)							
1	Strobe/Shutter	0	31	0.0%	12.2%	Closed	0(0%)
		32	63	12.5%	24.7%	Open	
		64	127	25.1%	49.8%	Synchronous strobe from slow to fast	
		128	159	50.2%	62.4%	Open	
		160	223	62.7%	87.5%	Random strobe from slow to fast	
		224	255	87.8%	100.0%	Open	
2	Intensity	0	255	0.0%	100.0%	No light → Full light	0(0%)
3		0	65535	0.0%	100.0%	Intensity fade, fine (LSB)	
4	Total Red	0	255	0.0%	100.0%	No light → Full light	0(0%)
5		0	65535	0.0%	100.0%	Intensity fade, fine (LSB)	
6	Total Green	0	255	0.0%	100.0%	No light → Full light	0(0%)

7		0	65535	0.0%	100.0%	Intensity fade, fine (LSB)	
8	Total Blue	0	255	0.0%	100.0%	No light → Full light	0(0%)
9		0	65535	0.0%	100.0%	Intensity fade, fine (LSB)	
10	Total Whit	0	255	0.0%	100.0%	No light → Full light	0(0%)
11		0	65535	0.0%	100.0%	Intensity fade, fine (LSB)	
12	Rainbow Function	0	9	0.0%	3.5%	No function	0(0%)
		10	39	3.9%	15.3%	Rainbow scene 1	
		40	71	15.7%	27.8%	Rainbow scene 2	
		72	103	28.2%	40.4%	Rainbow scene 3	
		104	135	40.8%	52.9%	Rainbow scene 4	
		136	167	53.3%	65.5%	Rainbow scene 5	
		168	199	65.9%	78.0%	Rainbow scene 6	
		200	231	78.4%	90.6%	Rainbow scene 7	
		232	255	91.0%	100.0%	Rainbow flow from slow to fast	
13	Color temperature	0	24	0.0%	9.4%	No function	0(0%)
		25	35	9.8%	13.7%	3200K	
		36	46	14.1%	18.0%	3400K	
		47	57	18.4%	22.4%	3600K	
		58	68	22.7%	26.7%	3800K	
		69	79	27.1%	31.0%	4000K	
		80	90	31.4%	35.3%	4200K	
		91	101	35.7%	39.6%	4400K	
		102	112	40.0%	43.9%	4600K	
		113	123	44.3%	48.2%	4800K	
		124	134	48.6%	52.5%	5000K	
		135	145	52.9%	56.9%	5200K	
		146	156	57.3%	61.2%	5400K	
		157	167	61.6%	65.5%	5600K	
		168	178	65.9%	69.8%	5800K	
		179	189	70.2%	74.1%	6000K	
		190	200	74.5%	78.4%	6200K	
		201	211	78.8%	82.7%	6400K	
		212	222	83.1%	87.1%	6600K	
		223	233	87.5%	91.4%	6800K	
234	244	91.8%	95.7%	7000K			
245	255	96.1%	100.0%	7200K			
14	Zoom	0	255	0.0%	100.0%	Near → Far	0(0%)
15		0	65535	0.0%	100.0%	Zoom, fine (LSB)	
16	Pan	0	255	0.0%	100.0%	Pan	0(0%)
17		0	65535	0.0%	100.0%	Pan, fine (LSB)	

18	Tilt	0	255	0.0%	100.0%	Tilt	46(18.0%)
19		0	65535	0.0%	100.0%	Tilt, fine (LSB)	
20	Scan speed	0	255	0.0%	100.0%	Scan speed from fast to slow	0(0%)
21	Dimmer Mode	0	5	0.0%	2.0%	M0:600Hz,Gama1.5,Smoth	0(0%)
		6	11	2.4%	4.3%	M1:600Hz,Gama1.5,Snap	
		12	17	4.7%	6.7%	M2:1200Hz,Gama1.5,Smoth	
		18	23	7.1%	9.0%	M3:1200Hz,Gama1.5,Snap	
		24	29	9.4%	11.4%	M4:600Hz,Gama2.0,Smoth	
		30	35	11.8%	13.7%	M5:600Hz,Gama2.0,Snap	
		36	255	14.1%	100.0%	Reserved	
22	Special controls	0	59	0.0%	23.1%	No function	0(0%)
		60	69	23.5%	27.1%	Reset all motor after 5 seconds	
		70	79	27.5%	31.0%	Scan motor reset after 5 seconds	
		80	89	31.4%	34.9%	Zoom motor reset after 5 seconds	
		90	119	35.3%	46.7%	No function	
		120	129	47.1%	50.6%	Built-in program 1	
		130	139	51.0%	54.5%	Built-in program 2	
		140	149	54.9%	58.4%	Built-in program 3	
		150	159	58.8%	62.4%	Built-in program 4	
		160	169	62.7%	66.3%	Built-in program 5	
		170	179	66.7%	70.2%	Built-in program 6	
		180	189	70.6%	74.1%	Built-in program 7	
		190	199	74.5%	78.0%	Built-in program 8	
		200	209	78.4%	82.0%	Built-in program 9	
		210	219	82.4%	85.9%	Built-in program 10	
		220	239	86.3%	93.7%	No function	
240	249	94.1%	97.6%	Dimmer mode set			
250	255	98.0%	100.0%	No function			

DMX protocol - Extended [38 channels]

DMX mode	Name	DMX value		DMX percentage		Function	Default DMX Value
Extended (38ch)							
1	Strobe/Shutter	0	31	0.0%	12.2%	Closed	0(0%)
		32	63	12.5%	24.7%	Open	
		64	127	25.1%	49.8%	Synchronous strobe from slow to fast	
		128	159	50.2%	62.4%	Open	
		160	223	62.7%	87.5%	Random strobe from slow to fast	
		224	255	87.8%	100.0%	Open	
2	Intensity	0	255	0.0%	100.0%	No light → Full light	0(0%)

3		0	65535	0.0%	100.0%	Intensity fade, fine (LSB)	
	Total Red	0	255	0.0%	100.0%	No light → Full light	0(0%)
		0	65535	0.0%	100.0%	Intensity fade, fine (LSB)	
	Total Green	0	255	0.0%	100.0%	No light → Full light	0(0%)
		0	65535	0.0%	100.0%	Intensity fade, fine (LSB)	
	Total Blue	0	255	0.0%	100.0%	No light → Full light	0(0%)
		0	65535	0.0%	100.0%	Intensity fade, fine (LSB)	
	Total Whit	0	255	0.0%	100.0%	No light → Full light	0(0%)
		0	65535	0.0%	100.0%	Intensity fade, fine (LSB)	
4	Red 1	0	255	0.0%	100.0%	No light → Full light	0(0%)
5		0	65535	0.0%	100.0%	Intensity fade, fine (LSB)	
6	Green 1	0	255	0.0%	100.0%	No light → Full light	0(0%)
7		0	65535	0.0%	100.0%	Intensity fade, fine (LSB)	
8	Blue 1	0	255	0.0%	100.0%	No light → Full light	0(0%)
9		0	65535	0.0%	100.0%	Intensity fade, fine (LSB)	
10	Whit 1	0	255	0.0%	100.0%	No light → Full light	0(0%)
11		0	65535	0.0%	100.0%	Intensity fade, fine (LSB)	
12	Red 2	0	255	0.0%	100.0%	No light → Full light	0(0%)
13		0	65535	0.0%	100.0%	Intensity fade, fine (LSB)	
14	Green 2	0	255	0.0%	100.0%	No light → Full light	0(0%)
15		0	65535	0.0%	100.0%	Intensity fade, fine (LSB)	
16	Blue 2	0	255	0.0%	100.0%	No light → Full light	0(0%)
17		0	65535	0.0%	100.0%	Intensity fade, fine (LSB)	
18	Whit 2	0	255	0.0%	100.0%	No light → Full light	0(0%)
19		0	65535	0.0%	100.0%	Intensity fade, fine (LSB)	
20	Red 3	0	255	0.0%	100.0%	No light → Full light	0(0%)
21		0	65535	0.0%	100.0%	Intensity fade, fine (LSB)	
22	Green 3	0	255	0.0%	100.0%	No light → Full light	0(0%)
23		0	65535	0.0%	100.0%	Intensity fade, fine (LSB)	
24	Blue 3	0	255	0.0%	100.0%	No light → Full light	0(0%)
25		0	65535	0.0%	100.0%	Intensity fade, fine (LSB)	
26	Whit 3	0	255	0.0%	100.0%	No light → Full light	0(0%)
27		0	65535	0.0%	100.0%	Intensity fade, fine (LSB)	
28	Rainbow Function	0	9	0.0%	3.5%	No function	0(0%)
		10	39	3.9%	15.3%	Rainbow scene 1	
		40	71	15.7%	27.8%	Rainbow scene 2	
		72	103	28.2%	40.4%	Rainbow scene 3	
		104	135	40.8%	52.9%	Rainbow scene 4	
		136	167	53.3%	65.5%	Rainbow scene 5	
		168	199	65.9%	78.0%	Rainbow scene 6	
		200	231	78.4%	90.6%	Rainbow scene 7	

		232	255	91.0%	100.0%	Rainbow flow from slow to fast	
29	Color temperature	0	24	0.0%	9.4%	No function	0(0%)
		25	35	9.8%	13.7%	3200K	
		36	46	14.1%	18.0%	3400K	
		47	57	18.4%	22.4%	3600K	
		58	68	22.7%	26.7%	3800K	
		69	79	27.1%	31.0%	4000K	
		80	90	31.4%	35.3%	4200K	
		91	101	35.7%	39.6%	4400K	
		102	112	40.0%	43.9%	4600K	
		113	123	44.3%	48.2%	4800K	
		124	134	48.6%	52.5%	5000K	
		135	145	52.9%	56.9%	5200K	
		146	156	57.3%	61.2%	5400K	
		157	167	61.6%	65.5%	5600K	
		168	178	65.9%	69.8%	5800K	
		179	189	70.2%	74.1%	6000K	
		190	200	74.5%	78.4%	6200K	
		201	211	78.8%	82.7%	6400K	
212	222	83.1%	87.1%	6600K			
223	233	87.5%	91.4%	6800K			
234	244	91.8%	95.7%	7000K			
245	255	96.1%	100.0%	7200K			
30	Zoom	0	255	0.0%	100.0%	Near → Far	0(0%)
31		0	65535	0.0%	100.0%	Zoom, fine (LSB)	
32	Pan	0	255	0.0%	100.0%	Pan	0(0%)
33		0	65535	0.0%	100.0%	Pan, fine (LSB)	
34	Tilt	0	255	0.0%	100.0%	Tilt	46(18.0%)
35		0	65535	0.0%	100.0%	Tilt, fine (LSB)	
36	Scan speed	0	255	0.0%	100.0%	Scan speed from fast to slow	0(0%)
37	Dimmer Mode	0	5	0.0%	2.0%	M0:600Hz,Gama1.5,Smoth	0(0%)
		6	11	2.4%	4.3%	M1:600Hz,Gama1.5,Snap	
		12	17	4.7%	6.7%	M2:1200Hz,Gama1.5,Smoth	
		18	23	7.1%	9.0%	M3:1200Hz,Gama1.5,Snap	
		24	29	9.4%	11.4%	M4:600Hz,Gama2.0,Smoth	
		30	35	11.8%	13.7%	M5:600Hz,Gama2.0,Snap	
		36	255	14.1%	100.0%	Reserved	
38	Special controls	0	59	0.0%	23.1%	No function	0(0%)
		60	69	23.5%	27.1%	Reset all motor after 5 seconds	
		70	79	27.5%	31.0%	Scan motor reset after 5	

					seconds
	80	89	31.4%	34.9%	Zoom motor reset after 5 seconds
	90	119	35.3%	46.7%	No function
	120	129	47.1%	50.6%	Built-in program 1
	130	139	51.0%	54.5%	Built-in program 2
	140	149	54.9%	58.4%	Built-in program 3
	150	159	58.8%	62.4%	Built-in program 4
	160	169	62.7%	66.3%	Built-in program 5
	170	179	66.7%	70.2%	Built-in program 6
	180	189	70.6%	74.1%	Built-in program 7
	190	199	74.5%	78.0%	Built-in program 8
	200	209	78.4%	82.0%	Built-in program 9
	210	219	82.4%	85.9%	Built-in program 10
	220	239	86.3%	93.7%	No function
	240	249	94.1%	97.6%	Dimmer mode set
	250	255	98.0%	100.0%	No function

 Notes

Do not switch off the fixture within the first minute after switching on. Wait for at least 5 minutes to switch on the fixture.

Technical specification

Optical

- Light source: LED 30W (RGBW 4-in-1), quantity: 19pcs
- Expected average lifetime: 50000 hours
- Beam angle (zoom): 3° - 25°(50% peak angle), 7° - 50°(10% peak angle)
- Total Output (Lumen): 6447 lumens wide / 4834 lumens narrow
- Color temperature: 3200K-7200K linear regulation
- Mixing distance: 2m

Electrical

- Power input, nominal: AC 100-240V, 50/60Hz
- Max. Power consumption: 750W, max current: 3.3A, PF: 0.67
- Power supply unit: Narrow voltage Switching power

Control and programming

- Control channels (DMX): 22/22/38
- Protocol: DMX-512
- Display: Graphic LCD backlit

Physical / Installation

- Weight: 7.2 kg (16 lbs.)
- IP rating: IP20
- Material: Aluminum, steel, plastic
- Mounting points: Two quarter-turn locking points + attachment points for safety wire
- Minimum distance to combustible materials: 1.64ft. (0.5m)
- Minimum distance to illuminated surfaces: 3.28ft. (1m)

Dynamic effects

- Pan/Tilt movement: 540°/630° (Pan), 240° (tilt)
- Strobe: 1-25Hz, synchronized, pulse effects
- Dimmer: 0-100%, 16-bit, electronic linear dimming (600Hz/1200Hz smooth or snap dimmer mode optional)

Thermal

- Operating range: 5°F to 113°F (-15°C to +45°C)
- Startup range: -13°F to 113°F (-25°C to +45°C)
- Storage range: -40°F to 140°F (-40°C to +60°C)
- Cooling: Active fan
- Humidity: ≤85%

Connections

- AC power: Neutrik powerCon
- DMX data input/output: Chassis 5-pin (3-pin optional) XLR (in/out)

Certification and Safety

- EMC: EN 55103-1:2009, EN 55103-2:2009, EN 61000-3-2:2006+A2:2009, EN 61000-3-3:2013
- Safety: EN 60598-2-17:1989/A2:1991

Photometric

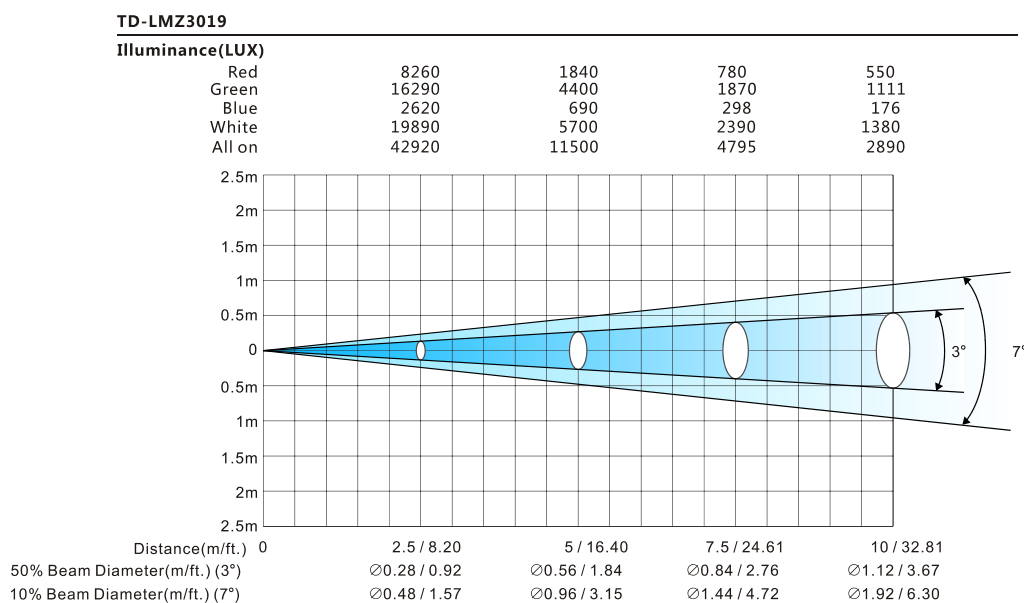

TD-LMZ3019

Illuminance(LUX)

Red	598	165	79	51
Green	1750	372	181	92
Blue	226	70	40	26
White	1851	481	244	141
All on	3679	908	484	264

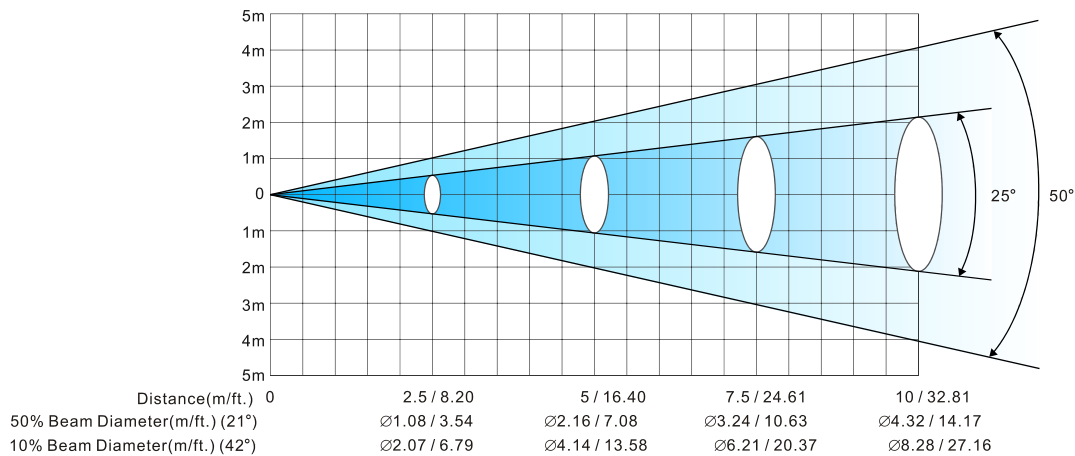

Other features

- Power setting: built-in continuous rechargeable battery, allowing setting functional data via LCD interface without power connection
- Sleep mode: When the lamp is disconnected from signal, the sleep mode is enabled automatically to make it more stable and safer. Sleep time can be customized.

Cleaning and maintenance

It is required that the fixture should be kept clean and well maintained to ensure its reliability. Its lifespan mainly depends on the working environment and proper operation. Should you have any questions, please consult a technical engineer of GTD Lighting.

⚠Notes

Damage resulted from dust, smoke, oil or improper use is not covered by warranty.

⚠Warning

Disconnect the fixture from AC power, and let it cool down for at least 15 minutes before opening the housing. Make sure to use a soft cloth to clean the optical components, and be careful, as the coating is easily scratched. Do not use any organic solvent such as alcohol to clean the reflector mirror, dichroic color filters or housing of the fixture.

- If the lens is cracked or otherwise damaged, replace it immediately.
- If the LED lamp becomes damaged or deformed in any way it must be replaced.
- If the light from the LED lamp appears dim, this normally indicates that it is reaching the end of its life span and should be changed at once. Aged LED lamps run to the extremity of their life might explode.
- If fixture does not function, check the fuse on the power socket of the fixture. Replace the fuse of the same specification if it is blown.
- The fixture is equipped with thermal-protection device that will switch off the LED lamp in case of overheating. If this happens, please check that the fans are not blocked, and clean them if they are dirty. Check whether the fans are operational. If not, call a qualified technician. Troubleshoot and correct the problem before switching on the

fixture again. Any maintenance work should only be carried out by qualified technicians.

Troubleshooting

Problem	Possible Cause	Suggested Correction
No response after connected to A/C power	Power switch not turned on.	Turn on power switch.
	Take out the fuse and check if it is blown.	Locate the blown fuse. Remove the broken fuse. Insert a replacement fuse of the correct amperage.
	Abnormal A/C input (A/C power socket, power cables, luminaire power socket).	Replace AC power socket and power cables, and then adjust power socket for proper connection.
	No DC voltage from switching power supply.	Check if the switching power supply has DC voltage output. Replace the switching power supply.
No response or wrong response to the commands of the control system	DMX cables disconnected from fixture's DATA IN connector.	Connect DMX cable to the fixture's DATA IN connector.
	Open circuit or short circuit fault in the DMX cables.	Replace DMX cables as required.
	Wrong DMX address for the fixture in the control system.	Ensure the address in "Run setting > Address Setting > Address" of the fixture is consistent with the address in the control system.
	Misuse in "Channel setting > Channel Mode" of the fixture.	Choose the channel mode in "Channel setting > Channel Mode" of the fixture as required by the user.
	Malfunctioning of DMX cannon input/output connectors. No input/output voltage to the main control board of the fixture.	Troubleshooting the DMX XLR signal plate of the fixture, replace the main control board of the fixture.
LED lamp off	There is no signal output to the main control board PWM.	Replace the main control board or repair.
	No output to the drive board LED +/- LED- or drive board over-current, check line connector if contact bad.	Reconnect the terminal, replace the driver board
	Normal end of LED lamp life, bad welding or poor heat dispersion.	Repair or replace LED light source or replace the whole piece of aluminum board, remove the cooling system failure.
Decreased brightness, uneven pattern projections	LED lamp aging, check the service time of LED light source, test LED drive board's current.	Replace the LED light source or adjust the drive board's current. Reduce LED's brightness.
	Excessive dusts or smudges on the effect assembly, focus module and objective lens.	Follow the instructions stated in this user manual to clean the effect assembly, focus module and objective lens.
	Damaged or deformed effect assembly, focus module or objective lens.	Replace the damaged or deformed components.

System wiring diagram

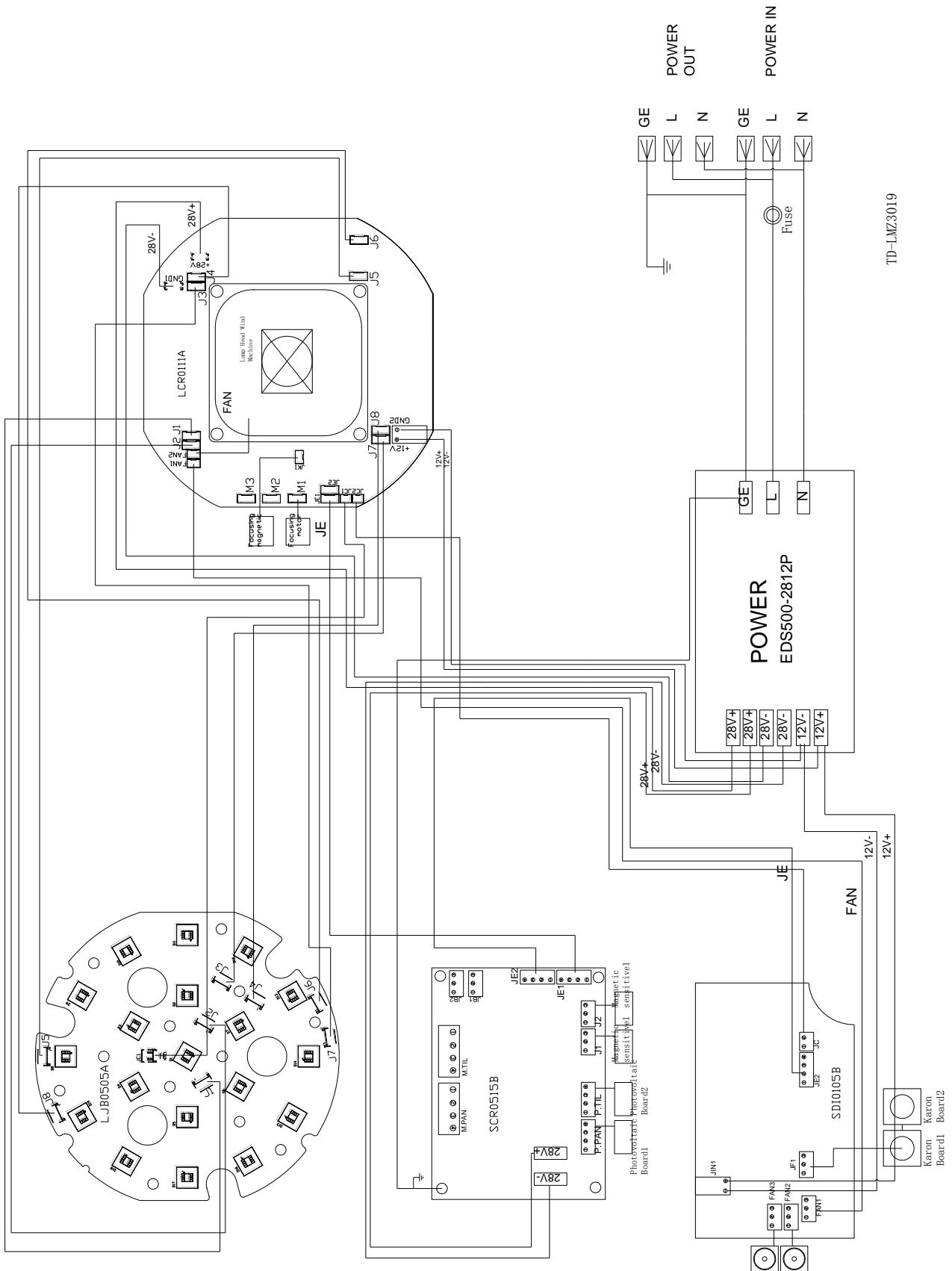

TD-LMZ3019

Spare parts list

Item	P/N	Qty	Notes
Switch power	1412050075A	1	LP500-176N28M-2 28V*17A 12V*2A
Aluminum Base Plate 0505A-2	5802010065A	1	LJB0505A
LMZ3019 display	5809210100A	1	LMZ3019-101E10 SDI0105B-1/LED display 0105B-1
LMZ3019 scan board	5809210101A	1	LMZ3019-201B10 SCR0515B/scan board0515B-1
LMZ3019 LED driver	5802030110A	1	LED driver 111A-1

Appendix 1

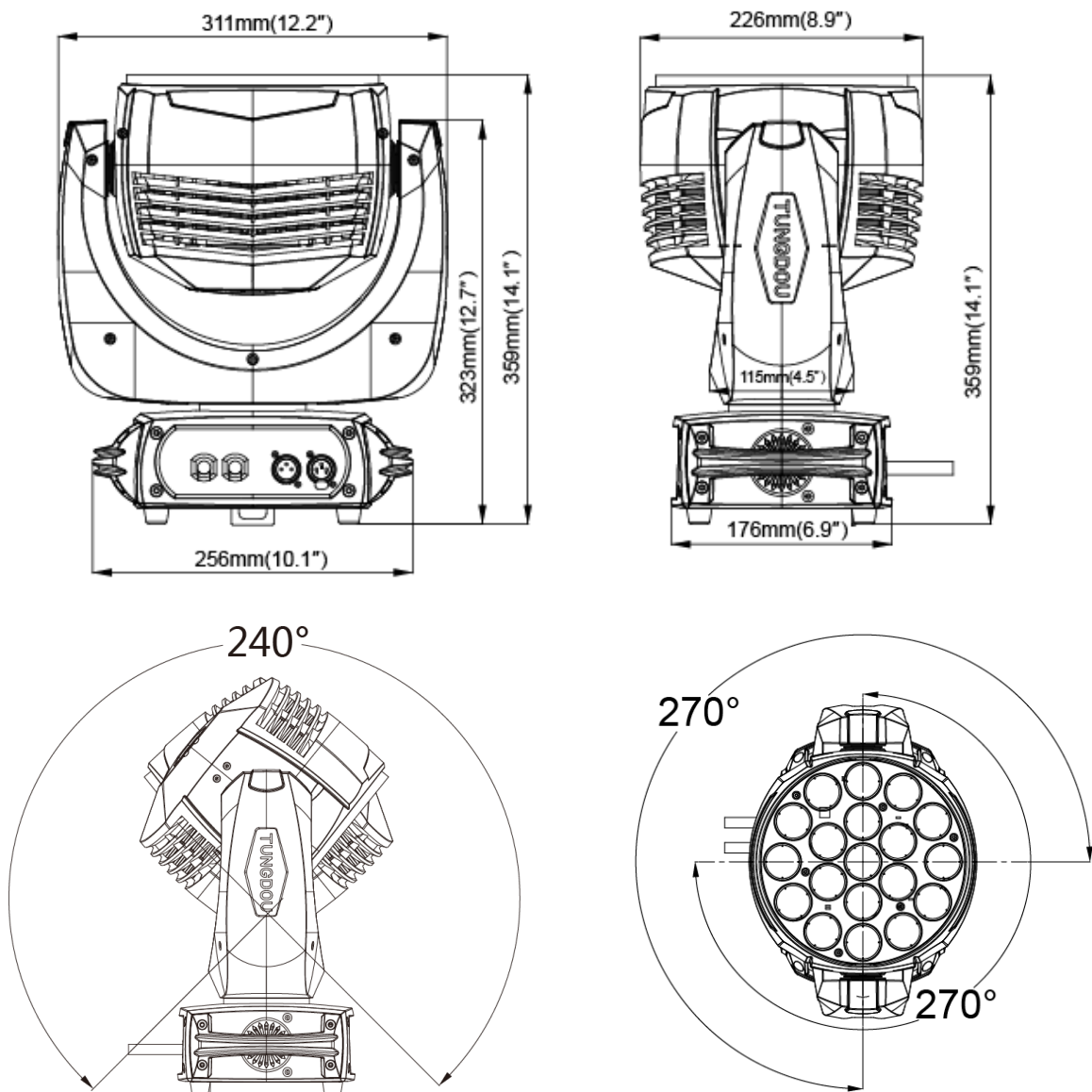

Notes:

P/N: 1502011087A

Time: August 30th, 2018