

GTD

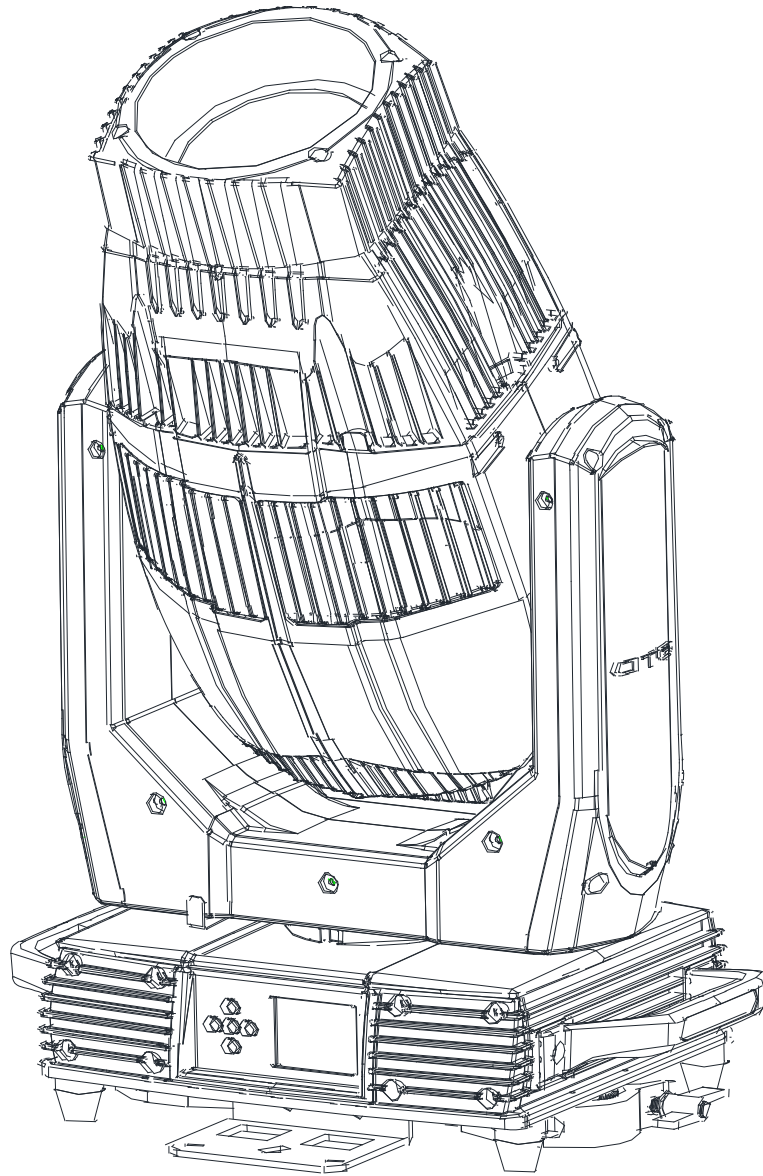

GTD-F3 II BSW

Moving Head

User Manual

GTD all rights reserved. Information, specifications, diagrams, images, and instructions herein are subject to change without notice. GTD logo and identifying product names and numbers herein are trademarks of GTD. Copyright protection claimed includes all forms and matters of copyrightable materials and information now allowed by statutory or judicial law or hereinafter granted. Product names used in this document may be trademarks or registered trademarks of their respective companies and are hereby acknowledged. All non-GTD brands and product names are trademarks or registered trademarks of their respective companies.

GTD and all affiliated companies hereby disclaim any and all liabilities for property, equipment, building, and electrical damages, injuries to any persons, and direct or indirect economic loss associated with the use or reliance of any information contained within this document, and/or as a result of the improper, unsafe, insufficient and negligent assembly, installation, rigging, and operation of this product.

Guangzhou GTD Culture & Technology Group Co.,Ltd. | 27 Fu Yuan Yi Road, Guangzhou 510805, P.R.China
+86-20-61808296 | +86-20-61812282 fax | www.gtd-lighting.com | contact@gtd-lighting.com

P/N: 1502011108A

Contents

1. Safety instructions.....	1
2. Product introductions.....	3
2.1 Dimensions.....	3
2.2 Fixture overview.....	4
2.3 Accessories.....	4
3. Packing and shipping.....	5
3.1 Protection lock.....	5
3.2 Unpacking.....	5
3.3 Packing after use.....	6
4. Installation.....	7
4.1 Clamps installation.....	7
4.2 Device installation.....	7
5. Power / Control connection	8
5.1 Power connection.....	8
5.2 Control connection.....	8
5.3 Testing.....	8
6. Control panel.....	9
6.1 Panel instruction.....	9
7. Technical specification.....	10
8. Gobos and colors.....	12
8.1 Gobos.....	12
8.2 Colors.....	12
9. Menu structure.....	14
10. DMX protocol.....	17
11. System wiring diagram.....	28
12. Maintenance and Troubleshooting.....	29
12.1 Cleaning and maintenance.....	29
12.2 Troubleshooting.....	29
13. Spare parts list.....	32

1. Safety instructions

Before using the fixture, read the latest version of the product user manual, paying particular attention to the safety instructions. Please check www.gtd-lighting.com for the latest revision/update of the user manual.



The manufacture of this fixture, are not responsible for damages, resulting from misuse of this fixture, due to the disregard of the information printed in this user manual.



DANGER!

Hazardous voltage. Risk of lethal or severe electric shock



WARNING!

Wear protective eyewear. Never look directly into the light source.



WARNING!

Burn hazard. Hot surface. Do not touch.



Only to direct mounting on non-combustible surfaces.



Replace all cracked glass shields.

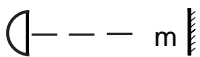

Minimum distance to lighted objects.

$t_a \dots ^\circ\text{C}$

Maximum ambient temperature.

$t_c \dots ^\circ\text{C}$

Maximum temp of the external surface.

General guidelines

- The protection rating of this product IP66.
- Never open this fixture while it is in use.
- The fixture should be kept clean. DO NOT operate the fixture in extreme heat or dusty environments. Avoid contact with chemical liquid.
- Minimum distance of inflammable materials from the surface 1.6 feet (0.5m).
- Maximum ambient temperature 113°F (45°C).
- Maximum temp of the external surface 176°F (80°C).
- Minimum distance to lighted objects must be 15m (49.21 feet).
- Lamp should be replaced if damaged or distorted in shape due to extreme heat.
- Cover, prism or LCD Menu Function Display with visible damages such as cracks or scratches must be replaced to ensure performance of the fixture.
- Disconnect the fixture from power before changing any parts or accessories.
- Basic insulation should be maintained between the controllable device and the product power supply.
- Make sure that the installation area can hold a minimum point load of 10 times the weight of all installed fixtures, clamps, cables, auxiliary equipment, etc. Make sure that the cover, clamps and locks are undamaged. Certified safety cables must always be used when installing the fixture.
- The fixture is only intended for installation, operation and maintenance by qualified professional. Instructions stated in the manual must be complied.
- The fixture must be kept in a well-ventilated place at least 50 cm away from any wall surface. Check if the fans or ventilation openings are unblocked.
- This fixture uses discharge lamp. Avoiding reduce the lamp's life, wait at least 15 minutes after powering off to allow the unit to cool down before handling.
- To ensure operational safety, broken or damaged cables and light source can only be fixed or replaced by certified technicians, certified local distributors or the manufacturer.
- Do not stick filters or other materials onto the lens. Do not modify the fixture or install other than GTD manufactured parts.
- For questions regarding safety operation, please contact our technical personnel or call the service hotline +862061808296.

2. Production instructions

2.1 Dimension

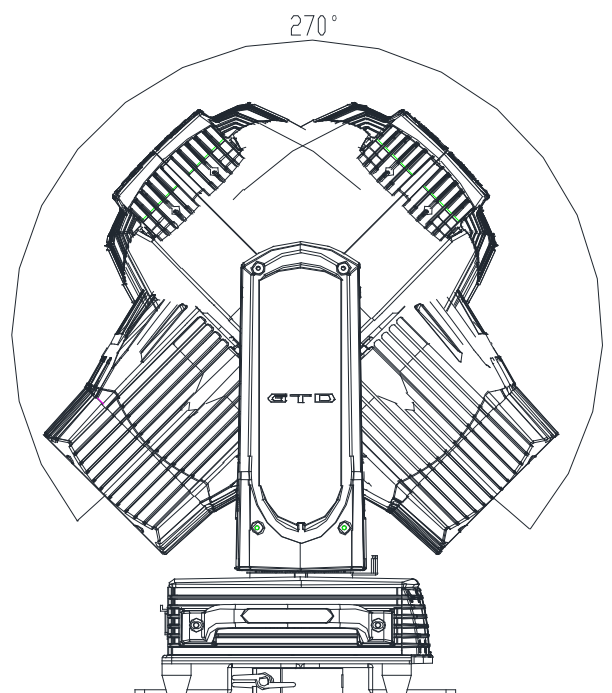
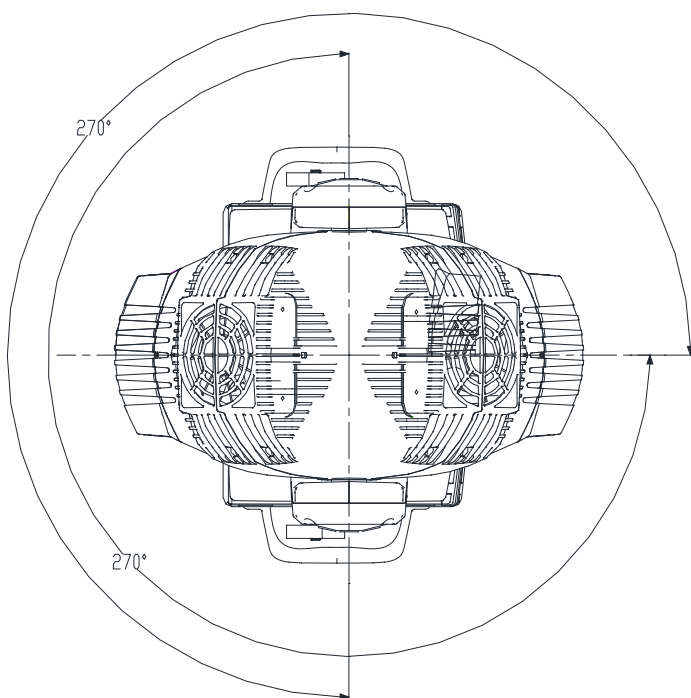
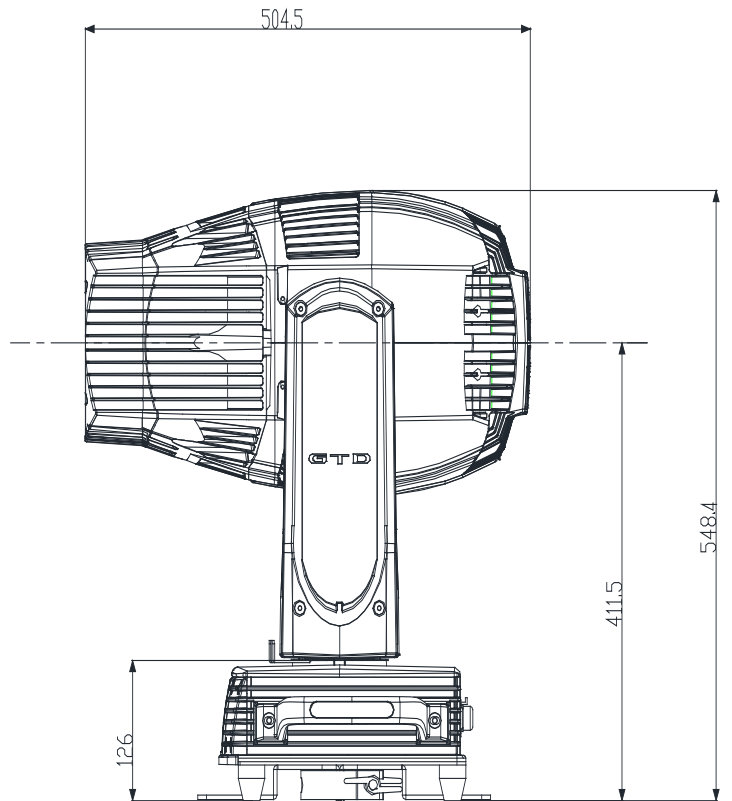
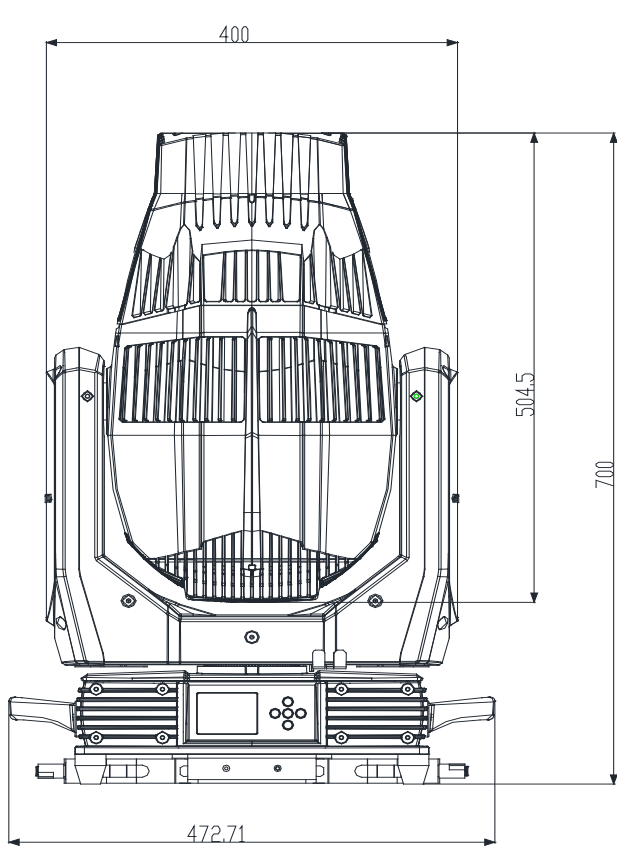

2.2 Fixture overview

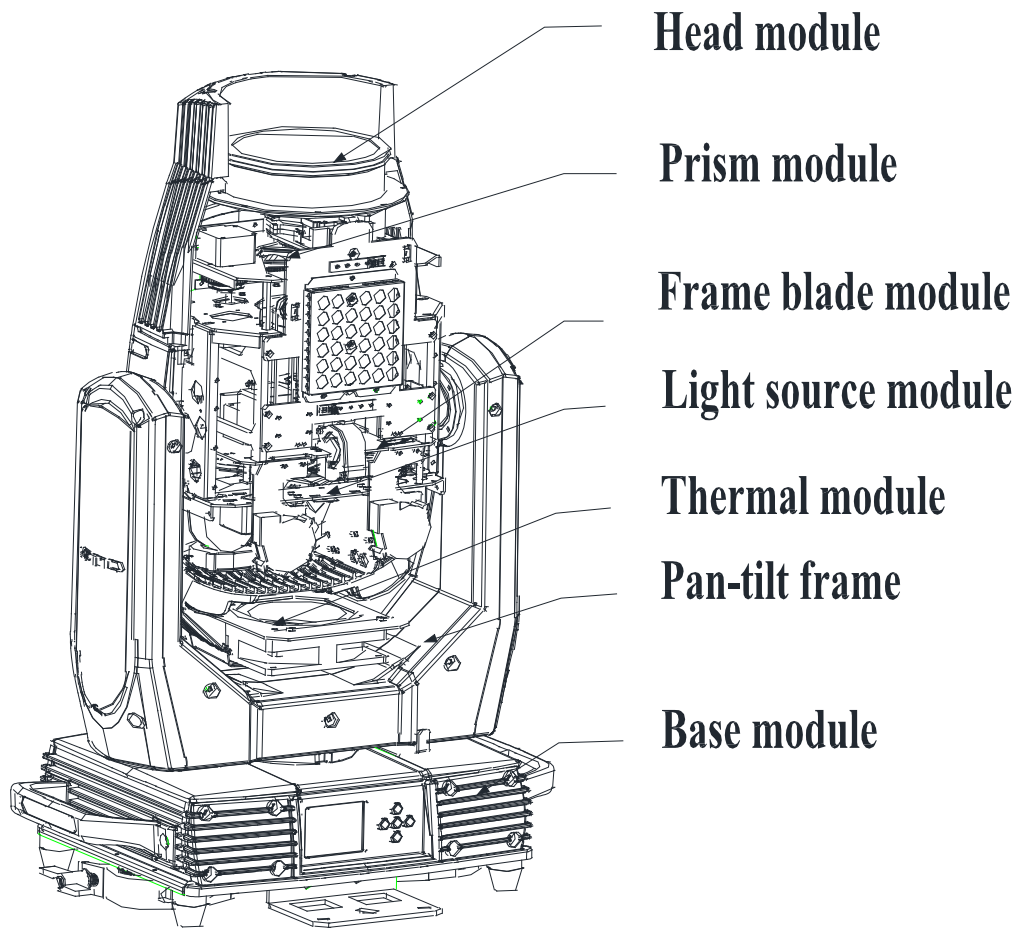

2.3 Accessories

Item	Qty	Unit	Remark
User Manual	1	Pc	--
Clamps	2	Set	Hanging integrated folding lamp.
Safety cable	1	Pc	Φ4*60cm 7*19 pc with hook Material: Steel
3-pins signal line	1	Set	1.5m*2.5mm ² connect blue plug

3. Packing and shipping

3.1 Protection lock

Pan and tilt locks are equipped to ensure safe transportation.

The horizontal axis has 4 locking points and the vertical axis has 5 locking points.

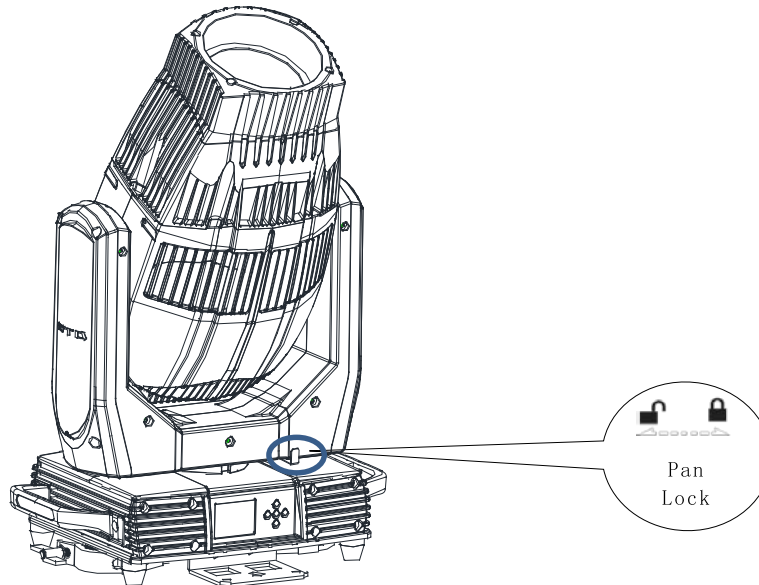

3.2 Unpacking

⚠ Notes

All products are quality controlled before they dispatched to customers. If the fixture is damaged during delivery, the customer must notify the shipper and manufacturer to file a damage insurance claim. Photographic evidence of the damage must be provided.

Flight–Case(specification: 575*525*690mm mm): Uncover the flight–case and remove the plastic packing bags. Hold the handles of the fixture firmly and take it out carefully.

Cardboard box(specification: 790*550*975mm): Open the box and take out the whole set of packaging foam which are contained both the fixture and its accessories. Remove the foam from the top, put away the accessories, and then take out the fixture wrapped in the plastic bag.

⚠ Notes

Check if the pan and tilt are locked before connecting the fixture to power

3.3 Packing after use

1. Switch off the fixture and wait for at least 5 minutes before disconnecting it from AC power. Cool down the fixture for at least 15 minutes before packing.
2. Lock pan and tilt.
3. Flight case: Wrap the fixture in plastic bags. Gripping the handle and then place it in the flight case along with all the accessories carefully. Close the cover lid. The wrap page are not allowed over 3 layers. Do not upside down.
4. Cardboard box: Wrap the fixture in plastic bags. Put it in the packaging foam along with all the accessories. Place the other set of packaging foam on top then put it carefully in the cardboard box.

4. Installation

4.1 Clamps installation

The fixture can be placed on the stage or mounted on the truss which faces any direction. Attach the clamps to the mounting position on the base of the fixture.

Warning: Use two clamps when mounting the fixture. Turn the screws attached to each clamp a 1/4 turn clockwise to lock. Always remember to use the safety cable which goes through the mounting hole on the base. Do not attach the safety cable on the handle.

4.2 Device installation

1. Make sure there is no damage on the clamps or safety cables before installation.

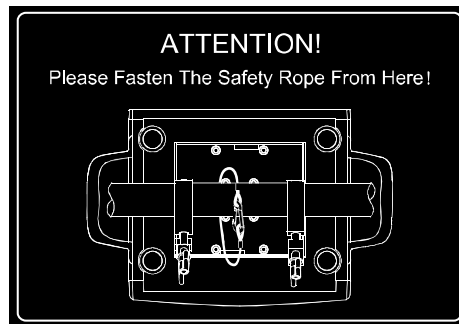

2. The clamp is mounted on the chassis of the fixture. Horizontally insert the clamp into the mounting holes of the chassis. Fasten the clamp tightly by a 1/4 turn clockwise. Fix another clamp in the same way.

3. Check if pan is locked before connecting the unit to AC power.

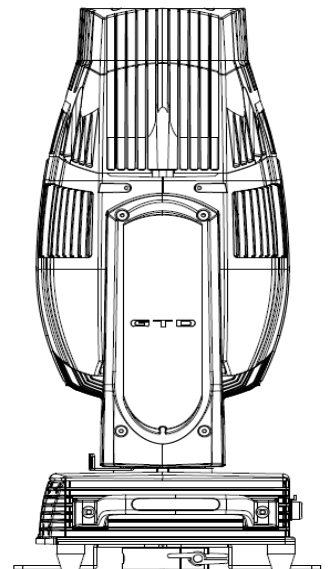
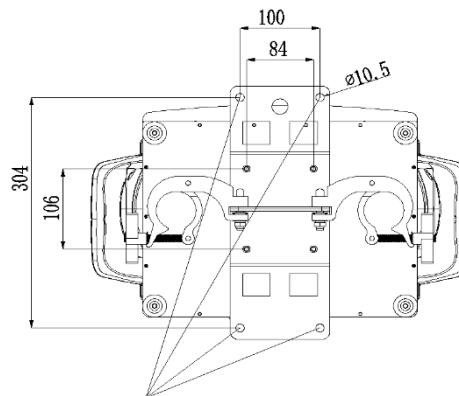
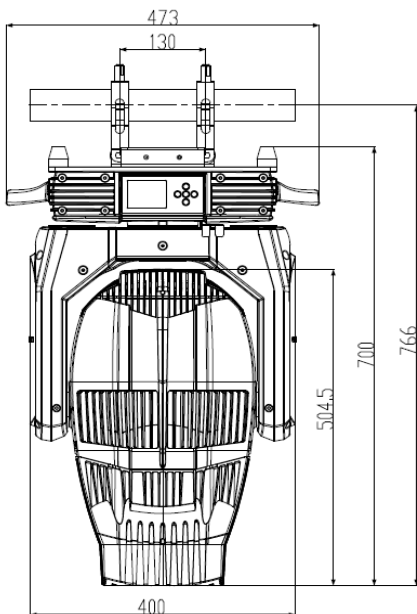

4.3 Lamps installation

1. Disconnect the power, cool down the fixture, and set the Tilt lock–catch on the arm in a horizontal position.
2. Use a screwdriver to rotate 1/4 circle counter–clockwise to unscrew the four quick bolts on the lamp’s back–cover.
3. Pull the back cover out gently in parallel direction by hands, and pull it in full place to let it drop down naturally.
4. Let the dot on the sphere of the lamp face to the back and the sphere face to the front, put the lamp horizontally into the slot on the lamp–holder and make sure that the lamp’s metal handle already be in alignment with the bayonet edge of the holder. Then press the metal legs at the ends of the lamp gently down to the right position, and make sure the lamp has been fixed well to the position.
5. And then push the back–holder with the fixed lamp gently into the reflector, observing the lamp after finishing, and plug in the windproof fan.

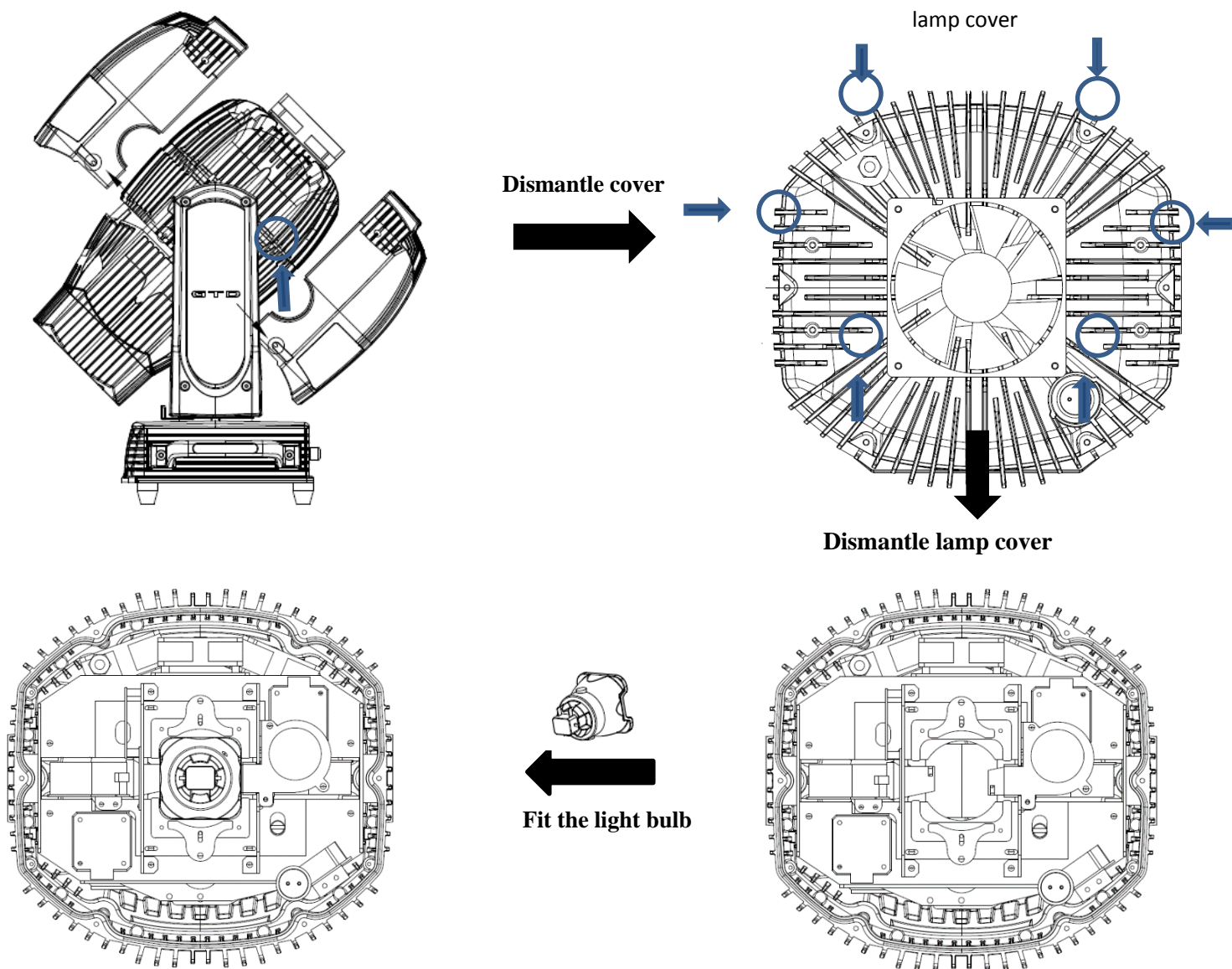

 **Attention**

The fixture is equipped with PHILIPS MSD Platinum Flex 300S which is featured with high efficiency and short-arc characteristic, such as a stable 7200K color-temperature and average lifespan of 6000h.

 **Attention**

1. There is potential damage to the fixture if fitting another type of lamp. Change the lamp before it reaches its lifespan. Read the guidelines in the package carefully when fixing the lamp.

2. To avoid any impact on the beam, do not touch the bulb with your bare hands. The lamp must be kept clean with the use of the clean paper contained in its package.

5. Power/ Control connection

5.1 Power connection

Connection method:

- L (Live) Brown wire
- E (Earth) Yellow / Green bi-color wire
- N (Neutral) Blue wire
- The numbers of series circuit: 6 (220VAC/50HZ)
- The voltage and frequency of the power source must be in compliance with the ones marked on the fixture. It is strongly recommended that each fixture are to be connected to the power source separately so that they can be switched on / off individually.

5.2 Control connection

The fixture has 3-pin XLR connectors for DMX data input and output as shown below. Connection between the console and fixture, and between fixtures must be made with 2 core screened DMX signal cable. Maximum connecting distance of signal cable is 150 meters. Additional DMX512 signal-amplifier is recommended for longer distance.

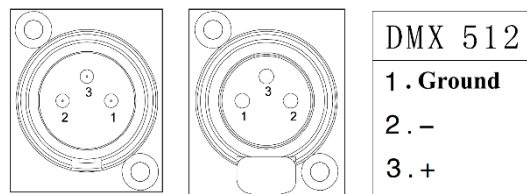

Connect the Console’s DMX OUTPUT to the first fixture’s DMX INPUT, then the first fixture’s DMX OUTPUT to the second fixture’s DMX INPUT and so on. It is recommended not to connect more than 32 units on a single DMX universe. On the last fixture’s output connect a DMX terminator. (The terminator is a 3-pin XLR connector with a 1/2W and 120Ω resistor between the pin 2 and pin 3) as shown below:

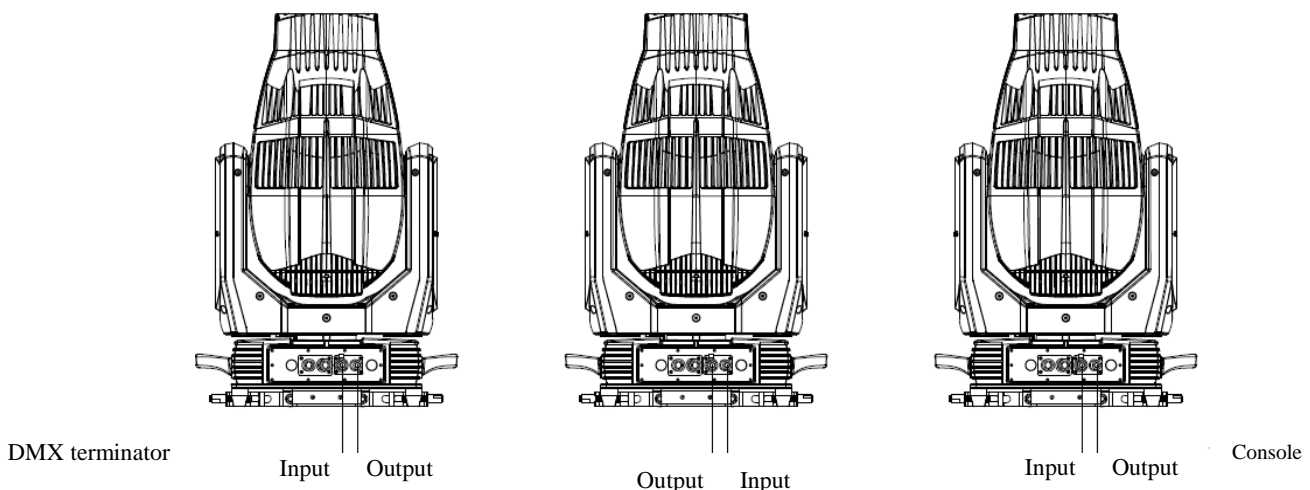

5.3 Testing

Connect the fixture to AC power. Check if the lamp is on and the fixture is independently controllable before putting into operation.

6. Control panel

6.1 Panel instruction



- The control panel features touch-sensitive buttons and LCD digital display for quick and easy setup of address code and functions menu.
- Press UP or DOWN to view or select the function menu.
- Press ENTER to choose a function and enter into corresponding submenu. Each menu represents a specific function of the fixture.
- Press RIGHT to select the specific function and save the changes or enter into the submenu, then press UP or DOWN to change the value of the selected function (increase or decrease).
- Press RIGHT to return to the previous menu or exit.

7. Technical specification

- **Optical**

Light source: PHILIPS MSD Platinum Flex 300S

Expected average lifetime: 6000 h

Color temperature correction: 7200K

Lumens: 16000lm

Zoom range: BEAM 0° ~ 2.5° / SPOT 3° ~ 43° / WASH 4° ~ 45°

CRI: Ra ≥ 80

Focus: with precision HD Glass lens, electronic linear focus clearly

Prism: 1 sixteen-prism, double opposite mirror

Frost: 1-independent frost effect

- **Gobo**

Rotating gobo wheel: 1 interchangeable gobo rotator, 8 optional pattern pieces,

Fixed gobo wheel: 6 gobos + open, CW/CCW rotation, variable speed.

Gobo outside diameter: 14.4mm

Max. Image diameter: 6mm

Max Thickness: 0.5mm

Gobo material: metal

- **Color**

Color wheel: 11 color gel and open gobo, linear adjustment function, “Rainbow effect” in both directions

- **Electrical**

Power input, nominal: AC 200-240V 50/60Hz

Max. Power consumption: 570W

Max current: 2.5A, PF: ≥ 0.99

Power supply unit: ≥ 0.99

Main fuse: 6.3A

Power input: Self-contained power cord

DMX data input/output: Chassis 3-pin

- **Control and programming**

Control channels (DMX): 19/16/22

Protocol: DMX-512 RDM

Display: LCD

- **Physical / Installation**

Weight: 28kg (61.73lbs.)

IP rating: IP66

Material: Aluminum, copper, steel, plastic, iron

Mounting points: 4 fixed folding lamp hook + attachment points for safety wire

- **Dynamic effects**

Pan/Tilt movement: 540°/270°, adopting a function which resets 32bit accurately and automatically

Strobe: 1-25Hz, strobe randomly, pulse randomly, strobe synchronously and asynchronously

Dimmer: 0-100%, mechanical linear dimming

- **Thermal**

- Operating range: 5°F to 113°F (-15°C to 45°C)
- Startup range: -13°F to 113°F(-25°C to 45°C)
- Storage range: -40°F to140°F(-40°C to60°C)
- Cooling: Active fan
- Humidity: ≤85%

- **Certification and Safety**

EMC: EN 55103-1:2009, EN 55103-2:2009, EN 61000-3-2:2006+A2:2009, EN 61000-3-3:2013, GB/T 17743-2007, GB 17625.1-2012

Safety: EN 60598-2-17:1989/A2:1991, GB 7000.1-2015, GB 7000.217-2008

- **Photometric**

BEAM

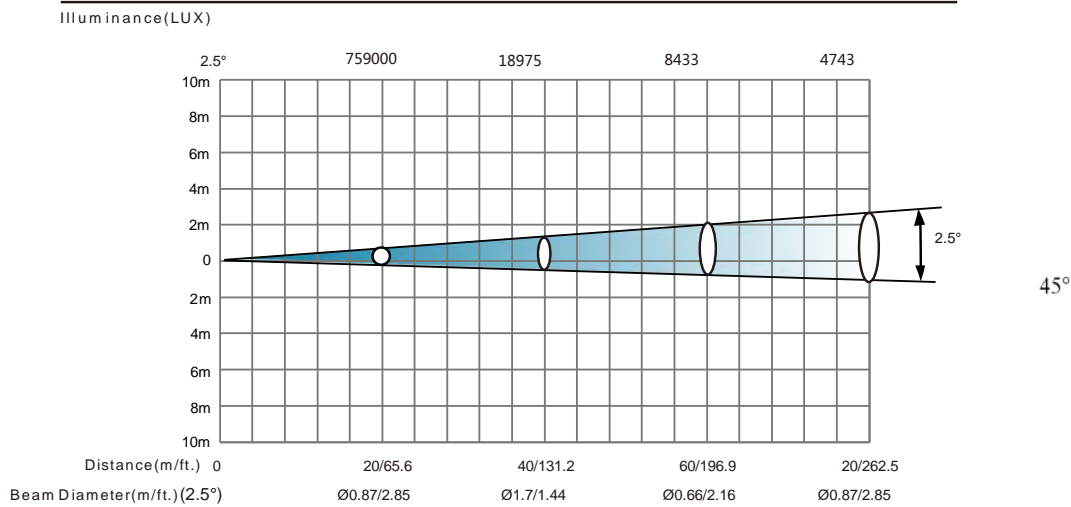

SPOT

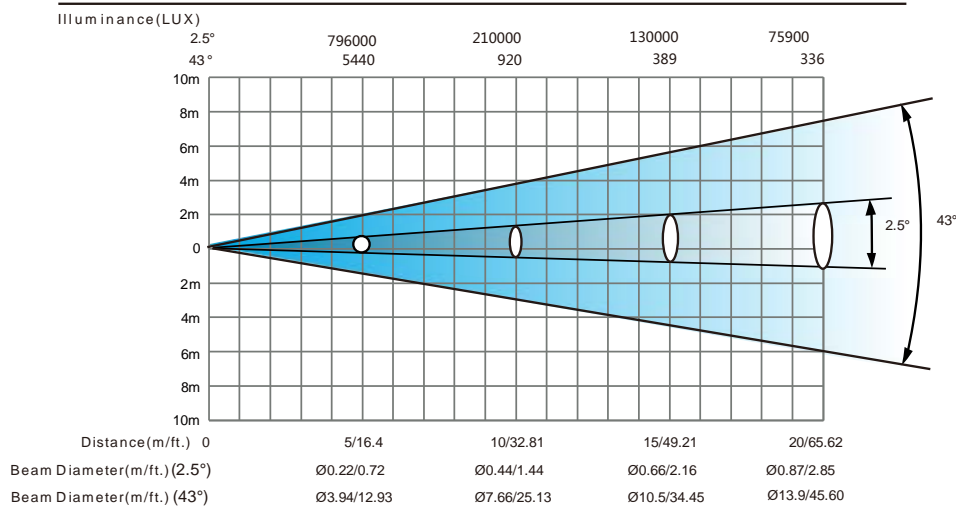

WASH

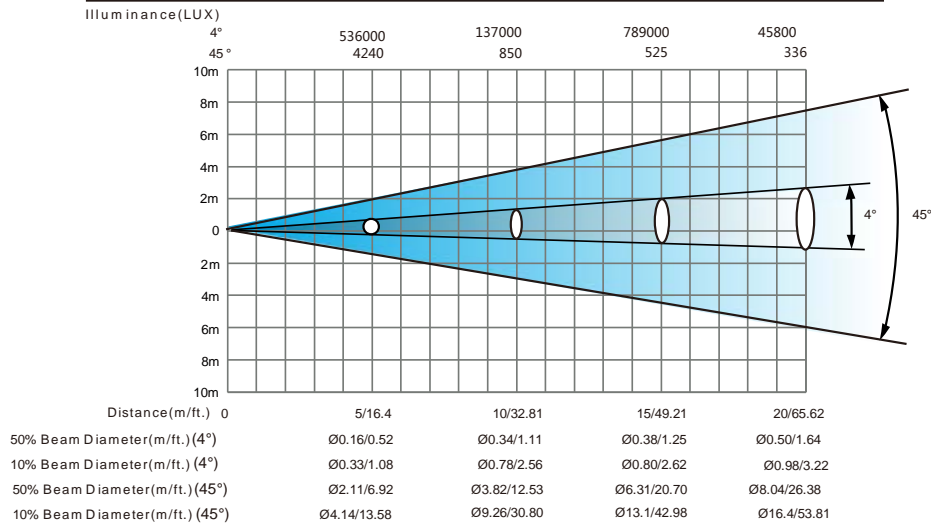

● Other features

- Enhanced stability of the fixture due to the wide input voltage AC/DC switching power supply which both reduces the impact of power and voltage fluctuations, and removes the restriction of voltage and frequency variations in different countries.
- Automatic energy saving: when the shutter or CMY is closed, power consumption will be reduced automatically with the photoelectric tracking induction technology.
- Sleep mode: uses the most advanced technology to activate sleep mode remotely. When the fixture is disconnected from signal, the sleep mode is enabled automatically to make it more stable and safer. Sleep time can be customized.
- Communications Design: DMX wired/wireless transmission, bidirectional-control technology, upgrade the software quickly and conveniently by using DMX cable.
- Thermal design: The wind drainage and intelligent temperature monitoring technology can monitor lighting's state : on /off. It can adjust the thermal design by the position's temperature of lighting so that the temperature can be controlled.

8. Gobos and colors

8.1 Gobo specification

All patterns are made onto the metal gobos, and can be customized according to user's requirement.

The customized size is as below:

Gobo material	Outer dimension	Effective dimension	Thickness
Glass gobo	Φ14.4mm	Φ6mm	0.5mm
Gobo material: Glass			

8.2 Gobos

One rotating gobo wheel: 7 interchangeable gobos + open, indexing, CW/CCW rotation, variable speed

One fixed gobo wheel: 7 gobos + open, CW/CCW rotation, variable speed.

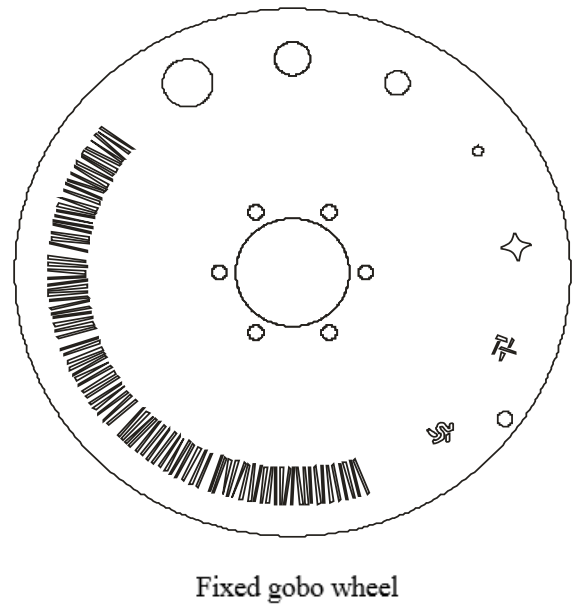
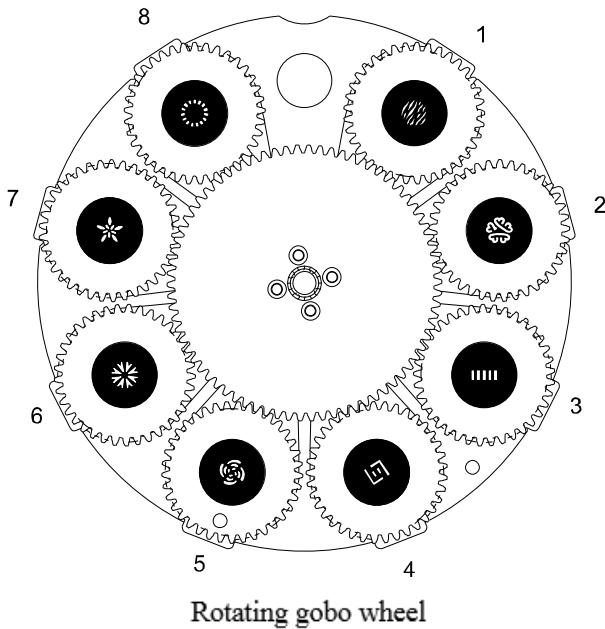

8.3 Colors

Color wheel: 9 colors + open, linear color conversion and "Half rainbow effect" in both direction.

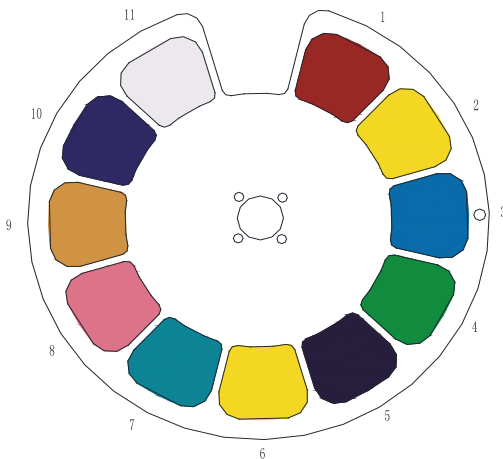

- | | | | |
|------------|-----------|----------------|----------|
| 1. RED | 2. ORANGE | 3. BLUE | 4. GREEN |
| 5. Magenta | 6. YELLOW | 7. CYAN | 8. PINK |
| 9. CTO | 10. UV | 11. CRI FILTER | |

9. Menu structure

Level 1	Level 2	Level 3	Level 4	Info
Run setting	Address Setting Value Display Auto-Program	Address: 001~ XXX Pan, All, No Master/Alone		Setting the DMX address Display the channel value Run auto program in master or slave
Device Info	Time Info	This Time Total Time Last Time Lamp On Time Lamp Off Time Last Time Code Clear Last Time Lamp Time Code Clear Lamp Time	XXXXXX Hour XXXXXX Hour XXXXXX Hour XXXXXX Hour XXXXXX Minute Password: xxx(88) Yes/No Password: xxx(111) Yes/No	Since power on time Product total run time Last product run time Lamp on time Lamp close time Clear last time password Clear last time Clear lamp time password Clear lamp time
	Temperature	Body Temperature	XXX 'C/'F	Body temperature
	Fans Info	NO/...		
	Err Info	No Err/...		
	Software Version	XX RDM Code0032- xxxxxx		The software version and RDM code
Lamp Control	Lamp On/Off Power On Lamp On Console Lamp On Console Lamp Off Lamp On Temp. Lamp Off Temp.	On/Off Enable/Disable Enable/Disable Enable/Disable 20~79, 45'C /68~174 , 113'F 80~139, 130'C/176~282,266'F		Open lamp Power on open lamp Console open lamp Console close lamp Open lamp below temperature Close lamp above temperature
System Setting	Status Setting	Console Set Addr No Signal Status Pan Reverse Tilt Reverse Pan Scan Degree Scan Feedback Standby Time	Enable/Disable Off/Hold/Auto/Music Enable/Disable Enable/Disable 360/540 Enable/Disable Disable/1~20 Min, 30	Address can be changed by console The status while no signal Pan Reverse Tilt Reverse Pan Scan Degree Scan Feedback Standby time
	Fan Speed	Smart Control High Speed Low Speed		Auto fans speed Fans high speed Fans low speed
	Display Setting	Backlight Time Keyboard Lock Brightness Set Language Auto Screen Set	1~80 Min/Disable Enable/Disable 15%~100% 80% Chinese/English on/off/Auto	Backlight off time Press <menu> 3s to unlock Brightness Set Change the language Screen display upside down
	Temperature Unit	Celsius		Temperature unit

		Fahrenheit		
	Value Default	Pan.....	Pan =XXX	The default value
	Wireless Dev	Wireless Off Wireless On Wireless Trans. Wireless Reset		Wireless off Wireless on Wireless transfer DMX data to another Wireless reset
	Dimmer Mode	M0:...~M5:... M1		Dimmer mode select
	Restore Default	Restore/Cancel		Restore to default value
Motor Reset	System Reset Scan Reset Color Reset Gobo Reset Strobe Reset Other Reset			System reset Pan and tilt motor reset color motor reset gobo motor reset strobe motor reset other motor reset
Channel Adjust	Test Mode	Pan.....		Every channel test
	Manual Mode	Pan:	Pan =XXX:	Manual control
	Adjust Mode	Input Password Pan:	Password=XXX(99) Pan=XXX:	The password of adjust mode Fixed all begin position
Channel Setting	Channel Mode	Standard Mode Simplified Mode Extended Mode Custom Mode A Custom Mode B Custom Mode C		Standard channel mode Simplified channel mode Extended channel mode Custom channel mode A Custom channel mode B Custom channel mode C
	Set CustomMode1 Set Custom Mode2 Set Custom Mode3	Max Channel Pan:	Channel = XX Pan = CH01:	Change the channel order
Program Edit	Select Group	Program Unit 1 Program Unit 2 Program Unit 3	Auto-Program 1 ~10 Auto-Program 1 ~10 Auto-Program 1 ~10	Choose build-in program for slave 1 Choose build-in program for slave 2 Choose build-in program for slave 3
	Program Edit	Auto-Program1: Auto-Program10	Program Test Step 1=Scene xxx Step 64=Scene xxx	Test the auto program The start scene of the program The end scene of the program
	Scene Edit	Scene Edit:001-250	Pan,..... (Pan=xxx) Scene T: (=xxxS) Rec. Outside	Edit the channel DMX Edit the scene time Get scene DMX form console
	Record Scene	Scene XX->XX		Record scene form console

*Settings highlighted in light grey are default values

10. DMX Protocol

Standard

DMX mode	Name	DMX value		DMX percentage		Function	Default DMX Value
Standard (19ch)							
1	Strobe/ Shutter	0	31	0.0%	12.2%	Closed	0(0%)
		32	63	12.5%	24.7%	Open	
		64	127	25.1%	49.8%	Synchronous strobe from slow to fast	
		128	159	50.2%	62.4%	Open	
		160	223	62.7%	87.5%	Random strobe from slow to fast	
		224	255	87.8%	100.0%	Open	
2	Intensity	0	255	0.0%	100.0%	No light → Full light	0(0%)
3		0	65535	0.0%	100.0%	Intensity fade, fine (LSB)	
4	Color wheel	0	17	0.0%	6.7%	Open	0(0%)
		18	27	7.1%	10.6%	Color 1	
		28	37	11.0%	14.5%	Color 2	
		38	47	14.9%	18.4%	Color 3	
		48	57	18.8%	22.4%	Color 4	
		58	67	22.7%	26.3%	Color 5	
		68	77	26.7%	30.2%	Color 6	
		78	87	30.6%	34.1%	Color 7	
		88	97	34.5%	38.0%	Color 8	
		98	107	38.4%	42.0%	Color 9	
		108	117	42.4%	45.9%	Color 10	
		118	127	46.3%	49.8%	Color 11	
		128	187	50.2%	73.3%	Color1 continous rotation CW from slow to fast	
		188	195	73.7%	76.5%	Stop	
196	255	76.9%	100.0%	Color1 continous contrarotation CCW from slow to fast			
5	Gobo wheel (static)	0	17	0.0%	6.7%	Open gobo	0(0%)
		18	22	7.1%	8.6%	Gobo 1	
		23	27	9.0%	10.6%	Gobo 2	
		28	32	11.0%	12.5%	Gobo 3	
		33	37	12.9%	14.5%	Gobo 4	
		38	42	14.9%	16.5%	Gobo 5	
		43	47	16.9%	18.4%	Gobo 6	
		48	52	18.8%	20.4%	Gobo 7	
		53	57	20.8%	22.4%	Open gobo	
		58	66	22.7%	25.9%	Gobo 1 shake	

DMX mode	Name	DMX value		DMX percentage		Function	Default DMX Value
Standard (19ch)							
5	Gobo wheel (static)	67	75	26.3%	29.4%	Gobo 2 shake	0(0%)
		76	84	29.8%	32.9%	Gobo 3 shake	
		85	93	33.3%	36.5%	Gobo 4 shake	
		94	102	36.9%	40.0%	Gobo 5 shake	
		103	111	40.4%	43.5%	Gobo 6 shake	
		112	120	43.9%	47.1%	Gobo 7 shake	
		121	127	47.5%	49.8%	Open gobo	
		128	187	50.2%	73.3%	Gobo wheel continous rotation CW from slow to fast	
		188	195	73.7%	76.5%	Stop	
		196	255	76.9%	100.0%	Gobo wheel continous contrarotation CCW from slow to fast	
6	Rotating gobo wheel	0	15	0.0%	5.9%	Open gobo	0(0%)
		16	22	6.3%	8.6%	Gobo 1	
		23	29	9.0%	11.4%	Gobo 2	
		30	36	11.8%	14.1%	Gobo 3	
		37	43	14.5%	16.9%	Gobo 4	
		44	50	17.3%	19.6%	Gobo 5	
		51	57	20.0%	22.4%	Gobo 6	
		58	64	22.7%	25.1%	Gobo 7	
		65	71	25.5%	27.8%	Gobo 8	
		72	78	28.2%	30.6%	Gobo 1 shake	
		79	85	31.0%	33.3%	Gobo 2 shake	
		86	92	33.7%	36.1%	Gobo 3 shake	
		93	99	36.5%	38.8%	Gobo 4 shake	
		100	106	39.2%	41.6%	Gobo 5 shake	
		107	113	42.0%	44.3%	Gobo 6 shake	
		114	120	44.7%	47.1%	Gobo 7 shake	
		121	127	47.5%	49.8%	Gobo 8 shake	
		128	187	50.2%	73.3%	Gobo wheel continous rotation CW from slow to fast	
188	195	73.7%	76.5%	Stop			
196	255	76.9%	100.0%	Gobo wheel continous contrarotation CCW from slow to fast			
7	Gobo rotating /positioning gobo wheel 1	0	127	0.0%	49.8%	Gobo rotation positioning	0(0%)
		128	187	50.2%	73.3%	Gobo continous rotation CW from slow to fast	
		188	195	73.7%	76.5%	Stop	
		196	255	76.9%	100.0%	Gobo continous contrarotation CCW from slow to fast	

DMX mode	Name	DMX value		DMX percentage		Function	Default DMX Value
Standard (19ch)							
8	Focus	0	255	0.0%	100.0%	Near →Far	0(0%)
9	Zoom	0	255	0.0%	100.0%	Near →Far	0(0%)
10	Prism plate1	0	31	0.0%	12.2%	Off	0(0%)
		32	255	12.5%	100.0%	Prism On	
11	Prism plate 1 rotation	0	127	0.0%	49.8%	Prism indexed	0(0%)
		128	187	50.2%	73.3%	Prism continous rotation CW from slow to fast	
		188	195	73.7%	76.5%	Stop	
		196	255	76.9%	100.0%	Prism continous contrarotation CCW from slow to fast	
12	Prism plate 2	0	31	0.0%	12.2%	Off	0(0%)
		32	255	12.5%	100.0%	Prism On	
13	Prism plate2 rotation	0	127	0.0%	49.8%	Prism indexed	0(0%)
		128	187	50.2%	73.3%	Prism continous rotation CW from slow to fast	
		188	195	73.7%	76.5%	Stop	
		196	255	76.9%	100.0%	Prism continous contrarotation CCW from slow to fast	
14	Frost	0	31	0.0%	12.2%	Off	0(0%)
		32	255	12.5%	100.0%	On	
15	Pan	0	255	0.0%	100.0%	Pan	0(0%)
16		0	65535	0.0%	100.0%	Pan, fine (LSB)	
17	Tilt	0	255	0.0%	100.0%	Tilt	46(18.0%)
18		0	65535	0.0%	100.0%	Tilt, fine (LSB)	
36	Scan speed	0	255	0.0%	100.0%	Scan speed from slow to fast	0(0%)
19	Special controls	0	9	0.0%	3.5%	No function	0(0%)
20	Special controls	10	19	3.9%	7.5%	Open light after 5 seconds	
		20	29	7.8%	11.4%	Close light after 5 seconds	
		30	39	11.8%	15.3%	Color wheel half color switch	
		40	49	15.7%	19.2%	Color wheel random positioning	
		50	59	19.6%	23.1%	Reserved	
		60	69	23.5%	27.1%	Reset all motor after 5 seconds	
		70	79	27.5%	31.0%	Scan motor reset after 5 seconds	
		80	89	31.4%	34.9%	All color motor reset after 5 seconds	
90	99	35.3%	38.8%	All gobo motor reset after 5 seconds			

DMX mode	Name	DMX value		DMX percentage		Function	Default DMX Value
Standard (19ch)							
20	Special controls	100	109	39.2%	42.7%	All strobe motor reset after 5 seconds	
		110	119	43.1%	46.7%	Other motor reset after 5 seconds	
		120	129	47.1%	50.6%	Built-in program 1	
		130	139	51.0%	54.5%	Built-in program 2	
		140	149	54.9%	58.4%	Built-in program 3	
		150	159	58.8%	62.4%	Built-in program 4	
		160	169	62.7%	66.3%	Built-in program 5	
		170	179	66.7%	70.2%	Built-in program 6	
		180	189	70.6%	74.1%	Built-in program 7	
		190	199	74.5%	78.0%	Built-in program 8	
		200	209	78.4%	82.0%	Built-in program 9	
		210	219	82.4%	85.9%	Built-in program 10	
		220	255	86.3%	100.0%	Reserved	

Simplified

DMX mode	Name	DMX value		DMX percentage		Function	Default DMX Value
Simplified (16ch)							
1	Strobe/ Shutter	0	31	0.0%	12.2%	Closed	0(0%)
		32	63	12.5%	24.7%	Open	
		64	127	25.1%	49.8%	Synchronous strobe from slow to fast	
		128	159	50.2%	62.4%	Open	
		160	223	62.7%	87.5%	Random strobe from slow to fast	
		224	255	87.8%	100.0%	Open	
2	Intensity	0	255	0.0%	100.0%	No light→Full light	0(0%)
3	Color wheel	0	17	0.0%	6.7%	Open	0(0%)
		18	27	7.1%	10.6%	Color 1	
		28	37	11.0%	14.5%	Color 2	
		38	47	14.9%	18.4%	Color 3	
		48	57	18.8%	22.4%	Color 4	
		58	67	22.7%	26.3%	Color 5	
		68	77	26.7%	30.2%	Color 6	
		78	87	30.6%	34.1%	Color 7	
		88	97	34.5%	38.0%	Color 8	
		98	107	38.4%	42.0%	Color 9	
		108	117	42.4%	45.9%	Color 10	
		118	127	46.3%	49.8%	Color 11	
		128	187	50.2%	73.3%	Color1 continous rotation CW from fast to slow	
		188	195	73.7%	76.5%	Stop	
196	255	76.9%	100.0%	Color1 continous rotation CCW from slow to fast			
4	Gobo wheel (static)	0	17	0.0%	6.7%	Open gobo	0(0%)
		18	22	7.1%	8.6%	Gobo 1	
		23	27	9.0%	10.6%	Gobo 2	
		28	32	11.0%	12.5%	Gobo 3	
		33	37	12.9%	14.5%	Gobo 4	
		38	42	14.9%	16.5%	Gobo 5	
		43	47	16.9%	18.4%	Gobo 6	
		48	52	18.8%	20.4%	Gobo 7	
		53	57	20.8%	22.4%	Open gobo	
		58	66	22.7%	25.9%	Gobo 1 shake	
		67	75	26.3%	29.4%	Gobo 2 shake	
		76	84	29.8%	32.9%	Gobo 3 shake	
		85	93	33.3%	36.5%	Gobo 4 shake	
		94	102	36.9%	40.0%	Gobo 5 shake	
		103	111	40.4%	43.5%	Gobo 6 shake	

DMX mode	Name	DMX value		DMX percentage		Function	Default DMX Value
Simplified (16ch)							
4	Gobo wheel (static)	112	120	43.9%	47.1%	Gobo 7 shake	0(0%)
		121	127	47.5%	49.8%	Open gobo	
		128	187	50.2%	73.3%	Gobo wheel continuous rotation CW from slow to fast	
		188	195	73.7%	76.5%	Stop	
		196	255	76.9%	100.0%	Gobo wheel continuous contrarotation CCW from slow to fast	
5	Rotating gobo wheel	0	15	0.0%	5.9%	Open gobo	0(0%)
		16	22	6.3%	8.6%	Gobo 1	
		23	29	9.0%	11.4%	Gobo 2	
		30	36	11.8%	14.1%	Gobo 3	
		37	43	14.5%	16.9%	Gobo 4	
		44	50	17.3%	19.6%	Gobo 5	
		51	57	20.0%	22.4%	Gobo 6	
		58	64	22.7%	25.1%	Gobo 7	
		65	71	25.5%	27.8%	Gobo 8	
		72	78	28.2%	30.6%	Gobo 1 shake	
		79	85	31.0%	33.3%	Gobo 2 shake	
		86	92	33.7%	36.1%	Gobo 3 shake	
		93	99	36.5%	38.8%	Gobo 4 shake	
		100	106	39.2%	41.6%	Gobo 5 shake	
		107	113	42.0%	44.3%	Gobo 6 shake	
		114	120	44.7%	47.1%	Gobo 7 shake	
		121	127	47.5%	49.8%	Gobo 8 shake	
		128	187	50.2%	73.3%	Gobo wheel continuous rotation CW from slow to fast	
		188	195	73.7%	76.5%	Stop	
196	255	76.9%	100.0%	Gobo wheel continuous rotation CCW from slow to fast			
6	Gobo rotating/positioning gobo wheel 1	0	127	0.0%	49.8%	Gobo rotation positioning	0(0%)
		128	187	50.2%	73.3%	Gobo continuous rotation CW from slow to fast	
		188	195	73.7%	76.5%	Stop	
		196	255	76.9%	100.0%	Gobo continuous rotation CCW from slow to fast	
7	Focus	0	255	0.0%	100.0%	Near→Far	0(0%)
8	Zoom	0	255	0.0%	100.0%	Near→Far	0(0%)
9	Prism plate 1	0	31	0.0%	12.2%	Off	0(0%)
		32	255	12.5%	100.0%	Prism On	
10	Prism plate 1 rotation	0	127	0.0%	49.8%	Prism indexed	0(0%)
		128	187	50.2%	73.3%	Prism continuous rotation CW from slow to fast	

DMX mode	Name	DMX value		DMX percentage		Function	Default DMX Value
Simplified (16ch)							
10	Prism plate 1 rotation	188	195	73.7%	76.5%	Stop	
		196	255	76.9%	100.0%	Prism continuous rotation CCW from slow to fast	
11	Prism plate 2	0	31	0.0%	12.2%	Off	0(0%)
		32	255	12.5%	100.0%	Prism On	
12	Prism plate2 rotation	0	127	0.0%	49.8%	Prism indexed	0(0%)
		128	187	50.2%	73.3%	Prism continuous rotation CW from slow to fast	
		188	195	73.7%	76.5%	Stop	
		196	255	76.9%	100.0%	Prism continuous rotation CCW from slow to fast	
13	Frost	0	31	0.0%	12.2%	Off	0(0%)
		32	255	12.5%	100.0%	On	
14	Pan	0	255	0.0%	100.0%	Pan	0(0%)
15	Tilt	0	255	0.0%	100.0%	Tilt	46 (18.0%)
16	Special controls	0	9	0.0%	3.5%	No function	0(0%)
		10	19	3.9%	7.5%	Open light after 5 seconds	
		20	29	7.8%	11.4%	Close light after 5 seconds	
		30	39	11.8%	15.3%	Color wheel half color switch	
		40	49	15.7%	19.2%	Color wheel random positioning	
		50	59	19.6%	23.1%	Reserved	
		60	69	23.5%	27.1%	Reset all motor after 5 seconds	
		70	79	27.5%	31.0%	Scan motor reset after 5 seconds	
		80	89	31.4%	34.9%	All color motor reset after 5 seconds	
		90	99	35.3%	38.8%	All gobo motor reset after 5 seconds	
		100	109	39.2%	42.7%	All strobe motor reset after 5 seconds	
		110	119	43.1%	46.7%	Other motor reset after 5 seconds	
		120	129	47.1%	50.6%	Built-in program 1	
		130	139	51.0%	54.5%	Built-in program 2	
		140	149	54.9%	58.4%	Built-in program 3	
		150	159	58.8%	62.4%	Built-in program 4	
		160	169	62.7%	66.3%	Built-in program 5	
		170	179	66.7%	70.2%	Built-in program 6	
		180	189	70.6%	74.1%	Built-in program 7	
		190	199	74.5%	78.0%	Built-in program 8	
200	209	78.4%	82.0%	Built-in program 9			
210	219	82.4%	85.9%	Built-in program 10			
220	255	86.3%	100.0%	Reserved			

Extended

DMX mode	Name	DMX value		DMX percentage		Function	Default DMX Value
Extended (22ch)							
1	Strobe/Stutter	0	31	0.0%	12.2%	Closed	0(0%)
		32	63	12.5%	24.7%	Open	
		64	127	25.1%	49.8%	Synchronous strobe from slow to fast	
		128	159	50.2%	62.4%	Open	
		160	223	62.7%	87.5%	Random strobe from slow to fast	
		224	255	87.8%	100.0%	Open	
2	Intensity	0	255	0.0%	100.0%	No light → Full light	0(0%)
3		0	65535	0.0%	100.0%	Intensity fade, fine (LSB)	
4	Color wheel	0	17	0.0%	6.7%	Open	0(0%)
		18	27	7.1%	10.6%	Color 1	
		28	37	11.0%	14.5%	Color 2	
		38	47	14.9%	18.4%	Color 3	
		48	57	18.8%	22.4%	Color 4	
		58	67	22.7%	26.3%	Color 5	
		68	77	26.7%	30.2%	Color 6	
		78	87	30.6%	34.1%	Color 7	
		88	97	34.5%	38.0%	Color 8	
		98	107	38.4%	42.0%	Color 9	
		108	117	42.4%	45.9%	Color 10	
		118	127	46.3%	49.8%	Color 11	
		128	187	50.2%	73.3%	Color1 continuous rotation CW from fast to slow	
		188	195	73.7%	76.5%	Stop	
196	255	76.9%	100.0%	Color1 continuous rotation CCW from slow to fast			
5	Gobo wheel (static)	0	17	0.0%	6.7%	Open gobo	0(0%)
		18	22	7.1%	8.6%	Gobo 1	
		23	27	9.0%	10.6%	Gobo 2	
		28	32	11.0%	12.5%	Gobo 3	
		33	37	12.9%	14.5%	Gobo 4	
		38	42	14.9%	16.5%	Gobo 5	
		43	47	16.9%	18.4%	Gobo 6	
		48	52	18.8%	20.4%	Gobo 7	
		53	57	20.8%	22.4%	Open gobo	
		58	66	22.7%	25.9%	Gobo 1 shake	
		67	75	26.3%	29.4%	Gobo 2 shake	
		76	84	29.8%	32.9%	Gobo 3 shake	

DMX mode	Name	DMX value		DMX percentage		Function	Default DMX Value
Extended (22ch)							
5	Gobo wheel (static)	85	93	33.3%	36.5%	Gobo 4 shake	0(0%)
		94	102	36.9%	40.0%	Gobo 5 shake	
		103	111	40.4%	43.5%	Gobo 6 shake	
		112	120	43.9%	47.1%	Gobo 7 shake	
		121	127	47.5%	49.8%	Open gobo	
		128	187	50.2%	73.3%	Gobo wheel continous rotation CW from slow to fast	
		188	195	73.7%	76.5%	Stop	
		196	255	76.9%	100.0%	Gobo wheel continous contrarotation CCW from slow to fast	
		6	Rotating gobo wheel	0	15	0.0%	
16	22			6.3%	8.6%	Gobo 1	
23	29			9.0%	11.4%	Gobo 2	
30	36			11.8%	14.1%	Gobo 3	
37	43			14.5%	16.9%	Gobo 4	
44	50			17.3%	19.6%	Gobo 5	
51	57			20.0%	22.4%	Gobo 6	
58	64			22.7%	25.1%	Gobo 7	
65	71			25.5%	27.8%	Gobo 8	
72	78			28.2%	30.6%	Gobo 1 shake	
79	85			31.0%	33.3%	Gobo 2 shake	
86	92			33.7%	36.1%	Gobo 3 shake	
93	99			36.5%	38.8%	Gobo 4 shake	
100	106			39.2%	41.6%	Gobo 5 shake	
107	113			42.0%	44.3%	Gobo 6 shake	
114	120			44.7%	47.1%	Gobo 7 shake	
121	127			47.5%	49.8%	Gobo 8 shake	
128	187			50.2%	73.3%	Gobo wheel continous rotation CW from slow to fast	
188	195			73.7%	76.5%	Stop	
196	255			76.9%	100.0%	Gobo wheel continous rotation CCW from slow to fast	
7	Gobo rotating/positioning gobo wheel 1	0	127	0.0%	49.8%	Gobo rotation positioning	0(0%)
		128	187	50.2%	73.3%	Gobo continous rotation CW from slow to fast	
		188	195	73.7%	76.5%	Stop	
		196	255	76.9%	100.0%	Gobo continous rotation CCW from slow to fast	
8		0	65535	0.0%	100.0%	Gobo rotation/positioning, fine (LSB)	
9	Focus	0	255	0.0%	100.0%	Near →Far	0(0%)

DMX mode	Name	DMX value		DMX percentage		Function	Default DMX Value
Extended (22ch)							
10	Focus	0	65535	0.0%	100.0%	Focus, fine (LSB)	
11	Zoom	0	255	0.0%	100.0%	Near →Far	0(0%)
12		0	65535	0.0%	100.0%	Zoom, fine (LSB)	
13	Prism plate1	0	31	0.0%	12.2%	Off	0(0%)
		32	255	12.5%	100.0%	Prism On	
14	Prism plate 1 rotation	0	127	0.0%	49.8%	Prism indexed	0(0%)
		128	187	50.2%	73.3%	Prism continous rotation CW from slow to fast	
		188	195	73.7%	76.5%	Stop	
		196	255	76.9%	100.0%	Prism continous rotation CCW from slow to fast	
15	Prism plate 2	0	31	0.0%	12.2%	Off	0(0%)
		32	255	12.5%	100.0%	Prism On	
16	Prism plate2 rotation	0	127	0.0%	49.8%	Prism indexed	0(0%)
		128	187	50.2%	73.3%	Prism continous rotation CW from slow to fast	
		188	195	73.7%	76.5%	Stop	
		196	255	76.9%	100.0%	Prism continous rotation CCW from slow to fast	
17	Frost	0	31	0.0%	12.2%	Off	0(0%)
		32	255	12.5%	100.0%	On	
18	Pan	0	255	0.0%	100.0%	Pan	0(0%)
19		0	65535	0.0%	100.0%	Pan, fine (LSB)	
20	Tilt	0	255	0.0%	100.0%	Tilt	46
21		0	65535	0.0%	100.0%	Tilt, fine (LSB)	(18.0%)
22	Special controls	0	9	0.0%	3.5%	No function	0(0%)
		10	19	3.9%	7.5%	Open light after 5 seconds	
		20	29	7.8%	11.4%	Close light after 5 seconds	
		30	39	11.8%	15.3%	Color wheel half color switch	
		40	49	15.7%	19.2%	Color wheel random positioning	
		50	59	19.6%	23.1%	Reserved	
		60	69	23.5%	27.1%	Reset all motor after 5 seconds	
		70	79	27.5%	31.0%	Scan motor reset after 5 seconds	
		80	89	31.4%	34.9%	All color motor reset after 5 seconds	
		90	99	35.3%	38.8%	All gobo motor reset after 5 seconds	
		100	109	39.2%	42.7%	All strobe motor reset after 5 seconds	
		110	119	43.1%	46.7%	Other motor reset after 5 seconds	
		120	129	47.1%	50.6%	Built-in program 1	
		130	139	51.0%	54.5%	Built-in program 2	

DMX mode	Name	DMX value		DMX percentage		Function	Default DMX Value
Extended (22ch)							
22	Special controls	140	149	54.9%	58.4%	Built-in program 3	
		150	159	58.8%	62.4%	Built-in program 4	
		160	169	62.7%	66.3%	Built-in program 5	
		170	179	66.7%	70.2%	Built-in program 6	
		180	189	70.6%	74.1%	Built-in program 7	
		190	199	74.5%	78.0%	Built-in program 8	
		200	209	78.4%	82.0%	Built-in program 9	
		210	219	82.4%	85.9%	Built-in program 10	
		220	255	86.3%	100.0%	Reserved	

11. System wiring diagram

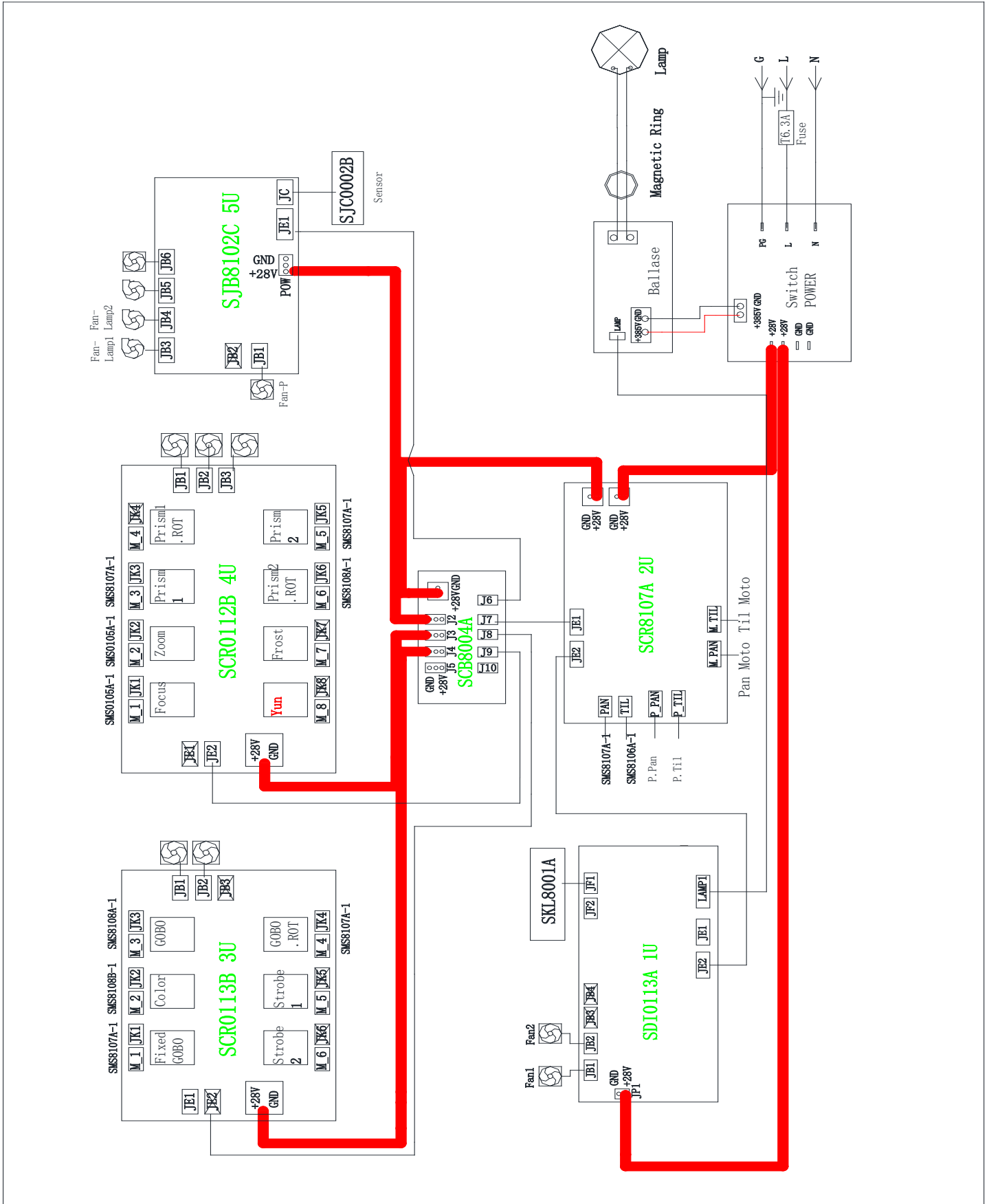

12. Maintenance and Troubleshooting

12.1 Cleaning and maintenance

It is required that the fixture should be kept clean and well maintained to ensure its reliability. Its lifespan mainly depends on the working environment and proper operation. Should you have any questions, please consult a technical engineer of GTD Lighting.

 Notes: Damage resulted from dust, smoke, oil or improper use is not covered by warranty.

 Notes: Disconnect the fixture from AC power, and let it cool down for at least 15 minutes before opening the housing. Make sure to use a soft cloth to clean the optical components, and be careful, as the coating is easily scratched. Do not use any organic solvent such as alcohol to clean the reflector mirror, dichroic color filters or housing of the fixture.

- If the lens is cracked or otherwise damaged, replace it immediately.
- If the lamp becomes damaged or deformed in any way it must be replaced.
- If the light from the lamp appears dim, this normally indicates that it is reaching the end of its life span and should be changed at once. Aged lamps run to the extremity of their life might explode.
- If fixture does not function, check the fuse on the power socket of the fixture. Replace the fuse of the same specification if it is blown.
- The fixture is equipped with thermal-protection device that will switch off the lamp in case of overheating. If this happens, please check that the fans are not blocked, and clean them if they are dirty. Check whether the fans are operational. If not, call a qualified technician.

12.2 Troubleshooting

Problem	Possible Cause	Suggested Correction
No response after connected to A/C power	Power switch not turned on.	Turn on power switch.
	Take out the fuse and check if it is blown.	Locate the blown fuse. Remove the broken fuse. Insert areplacement fuse of the correct amperage
	Abnormal A/C input (A/C power socket, power cables, luminaire power socket).	Replace AC power socket and power cables, and then adjust power socket for proper connection.
	No DC voltage from switching power supply.	Check if the switching power supply has DC voltage output. Replace the switching power supply.
No response or wrong response to the commands of the control system	DMX cables disconnected from fixture's DATA IN connector.	Connect DMX cable to the fixture's DATA IN connector.
	Open circuit or short circuit fault in the DMX cables.	Replace DMX cables as required.
	Wrong DMX address for the fixture in the control system.	Ensure the address in "Run setting > Address Setting >Address" of the fixture is consistent with the address in the control system.

Problem	Possible Cause	Suggested Correction
	Misuse in “Channel setting > Channel Mode of the fixture.	Choose the channel mode in “Channel setting > Channel Mode” of the fixture as required by the user
	Malfunctioning of DMX cannon input/output connectors. No input/output voltage to the main control board of the fixture.	Troubleshooting the DMX XLR signal plate of the fixture,replace the main control board of the fixture.
The lamp does not start when switch is turned on	Normal end of lamp life.	Test the lamp in an adjacent fixture which is known to be operating properly and then replace as necessary
	Whether the function of the relay board is intact, whether the signal is normal or not.	Repair or replace.
	Shorted leads between ballast and the lamp	Replace components as required.
	Incorrect ballast output.	Check ballast output to determine if it conforms to lamp requirements. If voltage and current do not stabilize in five to ten minutes warm-up time, ballast output is incorrect and adjustment should be made. Check capacitor wiring, if visibly available, to determine if capacitors are properly wired.
	Incorrect triggers output.	Replace triggers.
The lamp is off unexpected	The fixture is in sleep mode	Should the fixture is not in active use for “standby time”, the sleep mode is enabled automatically to make it more stable and safer, sleep time can be customized.
	Lamp has been operating: cool down time insufficient.	Environmental conditions such as extreme temperatures will have the fixture stop working, the lamps will require a period of time to cool and re-establish optimum starting conditions. Restart time varies with the degree of ventilation built into it, ambient temperature, and draft conditions.
	Overheat ballast resulting in premature failure or damaged ballast.	The ballast incorporate internal automatic-resetting thermal protection, which deactivates the ballast should it overheat. Normal operation resumes once the ballast has cooled sufficiently. Burned-out or failing lamps, or high temperatures in or around the fixture, can cause

Problem	Possible Cause	Suggested Correction
		the ballast to overheat, so we need solve the problem and replace components as required
	Thermostat damaged.	Replace.
Shaking, wrong position, and out of control gobo wheel	No function the connector between gobo wheel motor and drive, loose, damaged, or broken cables connecting the gobo wheel and drive.	Reconnect the gobo wheel motor to the drive, and replace cables as required.
	The gobo wheel motor's drive IC on the PCB might be out of condition.	Replace the drive having the same software version as required.
	Dislocated magnetic tube and positioning magnet, or damaged magnetic tube.	Calibrate the position of the magnetic tube to the positioning magnet, and replace magnetic tube as required
	Shaking motor, wrong rotation angle, losing step or damaged motor	Replace the motor as required.
Decreased brightness, uneven pattern projections	Normal end of lamp life.	Test the lamp in an adjacent fixture which is known to be operating properly and then replace as necessary
	The midline of the lamp is not aligned with the center point of the effect assembly (consisting of the rotating gobo wheel, static gobo wheel, color wheel, strobe, prism, and frost), focus module, and object lens.	Reinstall the lamp. Adjust the lamp position until the midline of the lamp is aligned with the center point of the effect assemblies (consisting of the rotating gobo wheel, static gobo wheel, color wheel, strobe, prism, frost, the focus adjusting module, and the object lens).
	Excessive dusts or smudges on the effect assembly, focus module and objective lens.	Follow the instructions stated in this user manual to clean the effect assembly, focus module and objective lens.
	Damaged or deformed effect assembly, focus module or objective lens.	Replace the damaged or deformed components
Wrong color	Normal end of lamp life	Test the lamp in an adjacent fixture which is known to be operating properly and then replace as necessary
	Excessive dusts or smudges on the rotating gobo wheel or color wheel.	Follow the instructions stated in this user manual to clean the rotating gobo wheel or color wheel.
	Rotating gobo wheel, color wheel with coating wearing off, damages or deformation	Replace the worn-off, damaged or deformed rotating gobo wheel and color wheel

Problem	Possible Cause	Suggested Correction
Non-clear shape	Excessive dusts or smudges on the rotating gobo wheel or color wheel	Follow the instructions stated in this user manual to clean the rotating gobo wheel or color wheel.
	Excessive dusts or smudges on the focus module or objective lens	Follow the instructions stated in this user manual to clean the focus module or objective lens
	Damaged or deformed focus module or objective lens.	Replace the damaged or deformed focus module or objective lens.

13. Spare parts list

Name	P/N	Qty	Notes
display panel	5809010533A	1	101J10 SDI0113A
Scanning plate	5809010534A	1	201N10 SCR8107A
drive board 1	5809010535A	1	301P10 SCR0113B
drive board 2	5809010536A	1	401P10 SCR0112B
LED drive board	5809010537A	1	501P10 SJB8102C

GTD

Guangzhou GTD Culture & Technology Group Co., Ltd.

Tel: 86-20-61808288

Fax: 86-20-61812282

<http://www.gtd-china.com>