



LED Flat Wash

GTD-LYS011764 (CW/WW)

User's Manual

Guangzhou GTD Lighting Technology Co., Ltd.

Tel: +86-20-61808296

Fax: +86-20-61812282

<http://www.gtd-lighting.com>







©2017 GTD all rights reserved. Information, specifications, diagrams, images, and instructions herein are subject to change without notice. GTD logo and identifying product names and numbers herein are trademarks of GTD. Copyright protection claimed includes all forms and matters of copyrightable materials and information now allowed by statutory or judicial law or hereinafter granted. Product names used in this document may be trademarks or registered trademarks of their respective companies and are hereby acknowledged. All non-GTD brands and product names are trademarks or registered trademarks of their respective companies.

GTD and all affiliated companies hereby disclaim any and all liabilities for property, equipment, building, and electrical damages, injuries to any persons, and direct or indirect economic loss associated with the use or reliance of any information contained within this document, and/or as a result of the improper, unsafe, insufficient and negligent assembly, installation, rigging, and operation of this product.

Contents

Safety instructions	3
General guidelines	4
Packing and shipping	5
Unpacking	5
Packing after use.....	5
Accessories	5
Product introduction	6
Installation	7
Clamps installation	7
Device installation	7
Power / Control connection	7
Power connection	7
Control connection	8
Testing	8
Control panel	8
Menu structure	9
DMX protocol	9
Technical specification	9
Cleaning and maintenance	11
Troubleshooting	12
System wiring diagram	13
Spare parts list	14
Appendix 1	14

Safety instructions

	<p>WARNING!</p> <p>Before using the fixture, read the latest version of the product user manual, paying particular attention to the safety instructions. Please check www.gtd-lighting.com for the latest revision/update of the user manual. The manufacture of this fixture, are not responsible for damages, resulting from misuse of this fixture, due to the disregard of the information printed in this user manual.</p>
	<p>DANGER!</p> <p>Hazardous voltage. Risk of lethal or severe electric shock.</p>
	<p>WARNING!</p> <p>Burn hazard. Hot surface. Do not touch.</p>
	<p>WARNING!</p> <p>Fire hazard.</p>
	<p>INDOORS USE ONLY!</p> <p>Do not expose fixture for rain and moisture.</p>
	<p>It's essential that the fixture is properly grounded. Only qualified personnel should perform electrical connections.</p>
	<p>WARNING!</p> <p>Wear protective eyewear. Never look directly into the light source.</p>

- Only qualified and certified personnel should perform installation of this fixture and only the original rigging parts (brackets) included with this fixture should be used for installation.
- Before applying power to the fixture, check that the source voltage matches the fixture's requirement. Every fixture must be earthed (grounded) and installed in accordance with local electricity regulations. Do not connect it to a dimmer system.
- Never look directly into the light source of this fixture to prevent risk of injury to your retina, which may induce blindness.

General guidelines

- Never open this fixture while in use.
- The fixture should be kept clean. **DO NOT** operate the fixture in extreme heat or dusty environments. Avoid contact with chemical liquid.
- This fixture is a professional light effect designed for **INDOOR / DRY LOCATIONS ONLY** on stage, in nightclubs, theatres, etc.
- **Minimum** distance to lighted objects must be **3.28feet (1m)**.
- **Maximum** temp of the external surface **140°F (60°C)**.
- **Maximum** ambient temperature **113°F (45°C)**.
- **Minimum** distance of inflammable materials from the surface **1.6 feet (0.5m)**.
- LED lamp should be changed if damaged or distorted in shape due to extreme heat.
- Cover, lens or Menu Function Display with visible damages such as cracks or scratches must be replaced to ensure performance of the fixture.
- Disconnect the fixture from power before changing any parts or accessories.
- Make sure that the installation area can hold a minimum point load of 10 times the weight of all installed fixtures, clamps, cables, auxiliary equipment, etc. Check that the cover, clamps and locks are undamaged. Certified safety cables must always be used when installing the fixture.
- The fixture is only intended for installation, operation and maintenance by qualified professional. Instructions stated in the manual must be complied.
- The fixture must be kept in a well-ventilated place at least 50 cm away from any wall surface. Check if the fans or ventilation openings are unblocked.
- Broken or damaged cables can only be fixed or changed by certified technicians, certified local distributors or the manufacturer to ensure operational safety.
- Do not stick filters or other materials onto the lens. Do not modify the fixture or install other than GTD manufactured parts.
- For questions regarding safety operation, please contact our technical personnel or call the service hotline +8620 61808296.

Packing and shipping

Unpacking

Notes

All products are quality controlled and checked for any faults before they are dispatched to customers. If the fixture is damaged during delivery, the customer must notify the shipper and manufacturer to file a damage insurance claim. Photographic evidence of the damage must be provided.

Flight-Case

Open the cover of the flight-case and remove the plastic packing bags. Hold the handles of the fixture firmly and take it out carefully.

Cardboard box

Open the box and take out the whole set of packaging foam which contains both the fixture and its accessories. Remove the foam from the top, put away the accessories, and then take out the fixture wrapped in the plastic bag.

Packing after use

1. Switch off the fixture and wait for at least 5 minutes before disconnecting it from AC power. Cool down the fixture for at least 15 minutes before packing.
2. Flight case: Wrap the fixture in plastic bags. Hold it by the handles, and then carefully place it inside the flight case along with all the accessories. Close the cover. Only 2 layers are allowed when piling up the flight cases. Do not upside down.

Cardboard box: Wrap the fixture in plastic bags. Put it in the packaging foam along with all the accessories. Place the other set of packaging foam on top then carefully put it inside the cardboard box.

Accessories

Item	Qty	Unit	Notes
User Manual	1	pc	
Clamp	1	pc	Ø42-52mm, Max. 200 kg
Power cable	1	pc	1.5m 2.0mm ²
Power Plugs	1	pc	NAC3FCB white

Notes

Accessories are subject to change without any prior written notice.

Product introduction

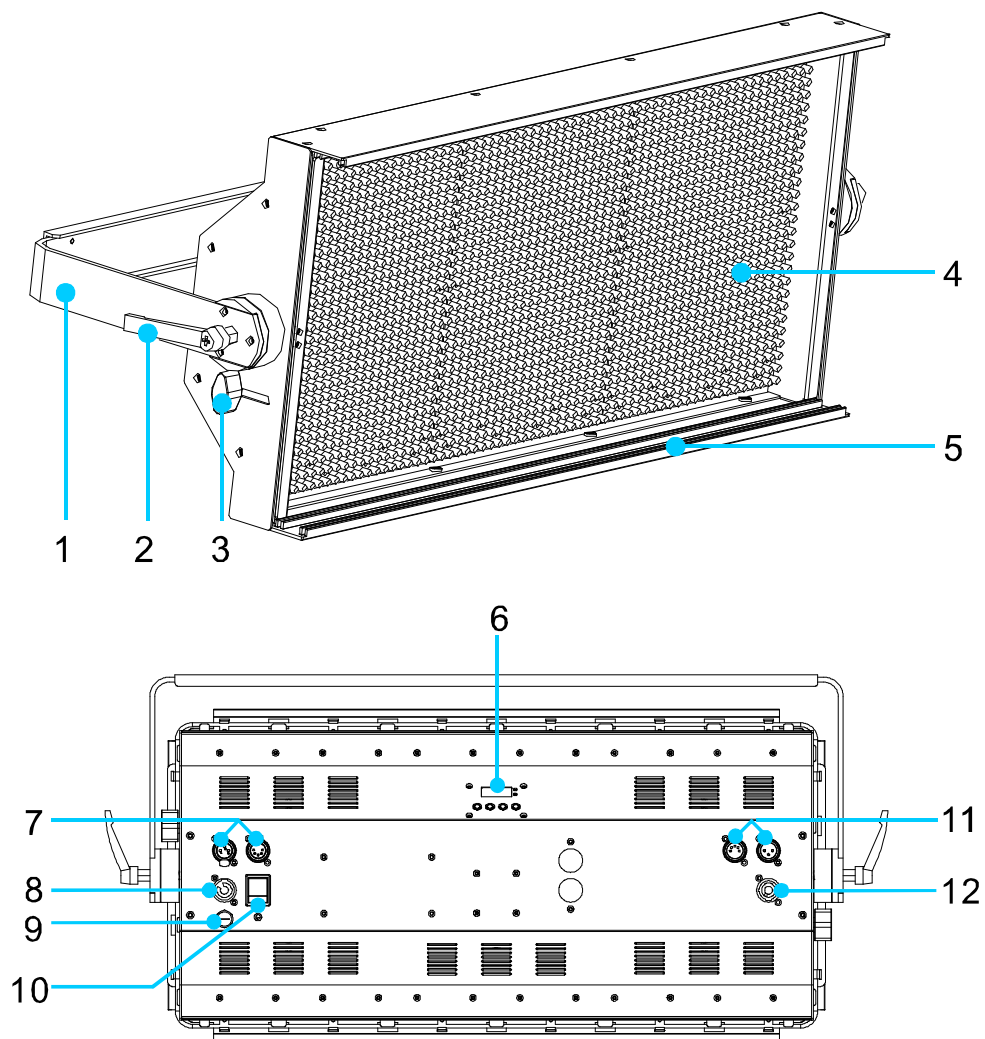

- | | | | | | |
|----|------------------------|----|---------------------------------|----|--------------|
| 1 | Arm bracket | 2 | Adjustable screw | 3 | Movable bolt |
| 4 | LED lamp | 5 | Slot for barn door installation | 6 | Display |
| 7 | DMX input(3 pin/5 pin) | 8 | Power input | 9 | Fuse |
| 10 | Power switch | 11 | DMX output(3 pin/5 pin) | 12 | Power output |

Installation

Clamps installation

The fixture can be placed on the stage or mounted on the truss facing any direction. Attach the clamp to the mounting position on the holder of the fixture.

⚠Warning

Use one clamp when mounting the fixture. Fasten the screw properly and connect a safety cable to fixture.

Device installation

1. Make sure there is no damage on the clamps or safety cables before installation.
2. The clamp is mounted on the holder of the fixture. Horizontally insert the clamp into the mounting holes of the holder. Fasten the clamp tightly.

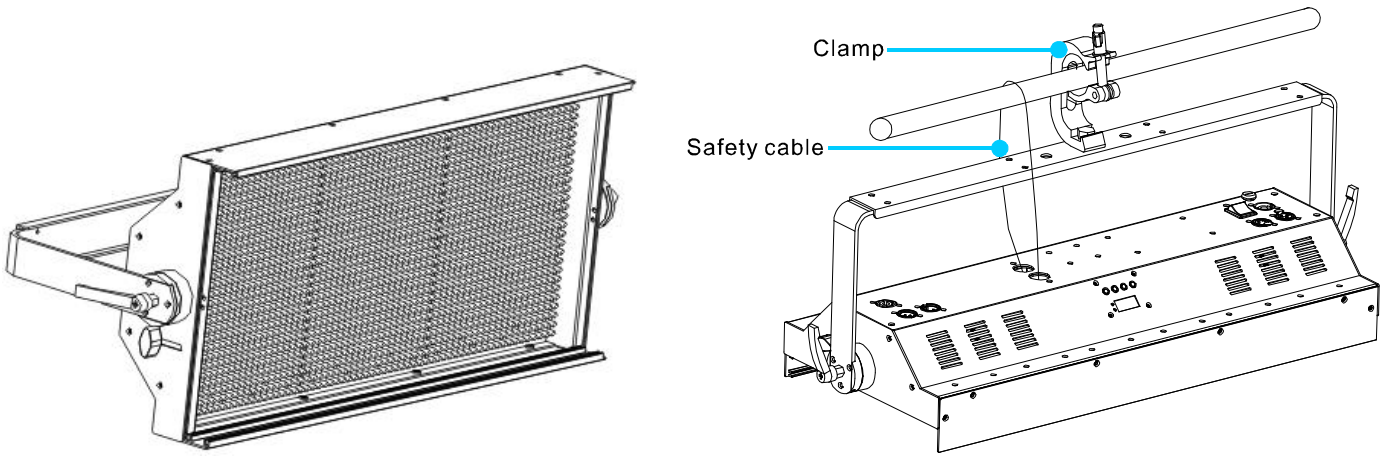

Power/ Control connection

Power connection

Connection method:

- L (Live) Brown wire
- E (Earth) Yellow / Green bi-color wire
- N (Neutral) Blue wire
- The voltage and frequency of the power source must be in compliance with the ones marked on the fixture. Please apply series connection when many sets of fixtures are connected to the power source to avoid heavy load to the power source. When the voltage is 110V, maximum 4 sets of fixtures could be allowed in each series connection. When the voltage is 220V, maximum 6 sets of fixtures could be allowed in each series connection. Another series connection should be set up for extra fixtures.

⚠Notes

It is essential that each fixture is correctly grounded and the electrical installation conforms to all relevant Standards / Codes of Practice for Safe Electrical Work.

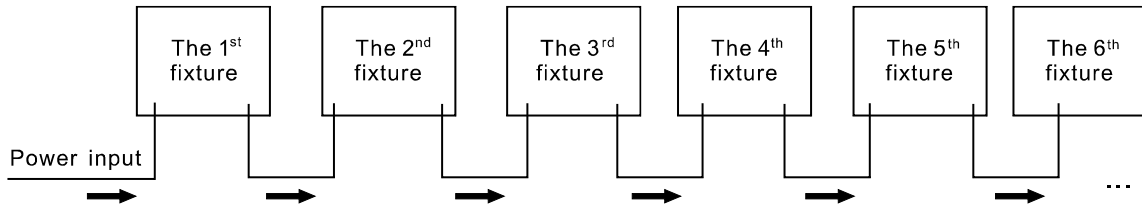

Control connection

The fixture has 5-pin and 3-pin XLR connectors for DMX data input and output as shown below. Connection between the console and fixture, and between fixtures must be made with 2 core screened DMX signal cable. Maximum connecting distance of signal cable is 150 meters. Additional DMX512 signal-amplifier is recommended for longer distance.

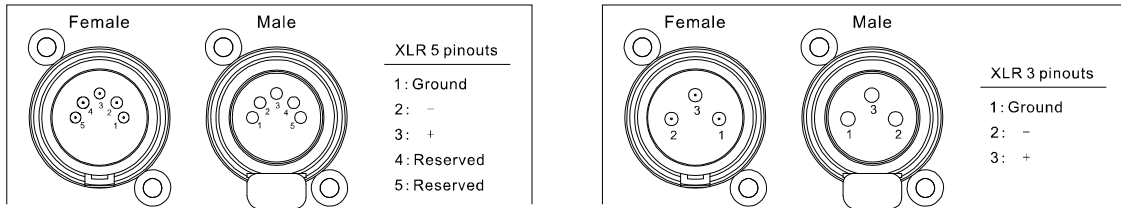

Connect the Console’s DMX OUTPUT to the first fixture’s DMX INPUT, then the first fixture’s DMX OUTPUT to the second fixture’s DMX INPUT and so on. It is recommended not to connect more than 32 units on a single DMX universe. On the last fixture’s output connect a DMX terminator. (The terminator is a XLR connector with a ¼ W and 120Ω resistor between the pin 2 and pin 3) as shown below:

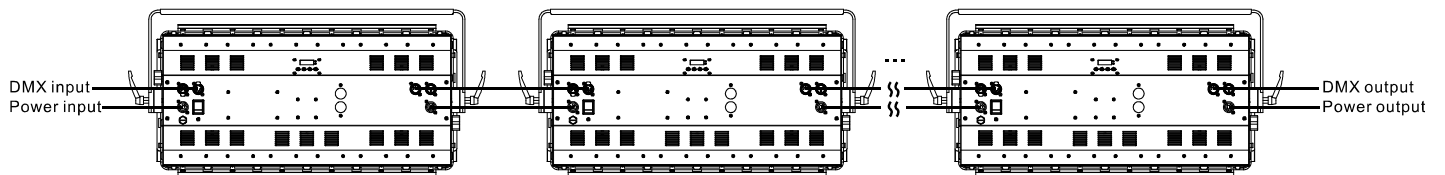

Testing

Connect the fixture to AC power. Check if the LED lamp is on and the fixture is independently controllable before putting into operation.

Control panel

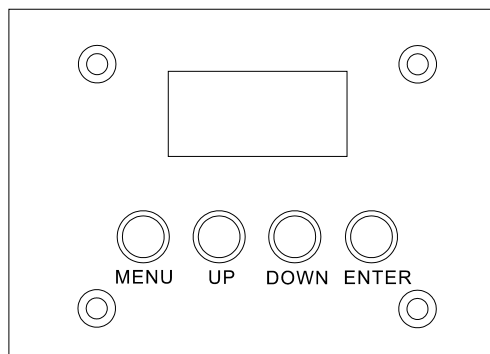

- The control panel with buttons and digital display can access the function menu and configure the fixture easily.
- Press MENU to check or modify the functions of the fixture; Press UP or DOWN to view or select the function menu.
- Press ENTER to choose a function and enter into corresponding sub menu. Each menu represents a specific function of the fixture.

- Press ENTER to select the specific function and save the changes or enter into the submenu, then press UP or DOWN to change the value of the selected function (increase or decrease).
- Press MENU to return to the previous menu or exit.

Menu structure

0	Addr	AXXX A001		DMX Address
1	DIMM	DXXX D255		static dimming
2	SET	RDMX	ON/OFF	change address values
		DISP	ON/OFF	reverse by 180°display
		Ver	V1.0~V9.9	software version

DMX protocol

Channel	Function	Value	Description
1	Dimmer	0-255	0-100%

Technical specification

Optical

- Light source: LED 0.1W, quantity: 1764pcs
- Expected average lifetime: 50000 hours
- Beam angle (fixed): 42°(50% peak angle), 78°(10% peak angle)

Photometric

- Color temperature: 5600K (CW) / 3200K (WW)
- CRI: >90Ra

Electrical

- Power input, nominal: AC 100-240W, 50/60Hz
- Max. Power consumption: 170W, max current: 1.7A, PF: 0.7
- Power supply unit: Auto-ranging electronic SMPS
- Main fuse: 250V/3.15A

Control and programming

- Control channels (DMX): 1
- Protocol: DMX-512
- Display: 4 x 8 segment display
- 16-bit control: Dimmer

Physical / Installation

- Weight: 10kg (22lbs.)
- IP rating: IP20
- Material: Aluminum, steel, plastic
- Mounting points: 12mm holes for G-Clamp
- Minimum distance to combustible materials: 1.64ft. (0.5m)
- Minimum distance to illuminated surfaces: 3.28ft. (1m)

Dynamic effects

- Pan/Tilt movement: Manually adjustable
- Dimmer: 0-100%, 16-bit, electronic linear dimming

Thermal

- Operating range: 14°F to 113°F (-10°C to +45°C)
- Startup range: 5°F to 113°F (-15°C to +45°C)
- Storage range: -40°F to 140°F (-40°C to +60°C)
- Cooling: Passive
- Humidity: ≤85%

Connections

- AC power: Neutrik powerCon
- DMX data input/output: Chassis 5-pin Neutrik XLR (in/out)

Certification and Safety

- EMC: EN 55103-1:2009, EN 55103-2:2009, EN 61000-3-2:2006+A2:2009, EN 61000-3-3:2013
- Safety: EN 60598-2-17:1989/A2:1991

Photometric

LYS011764CW:

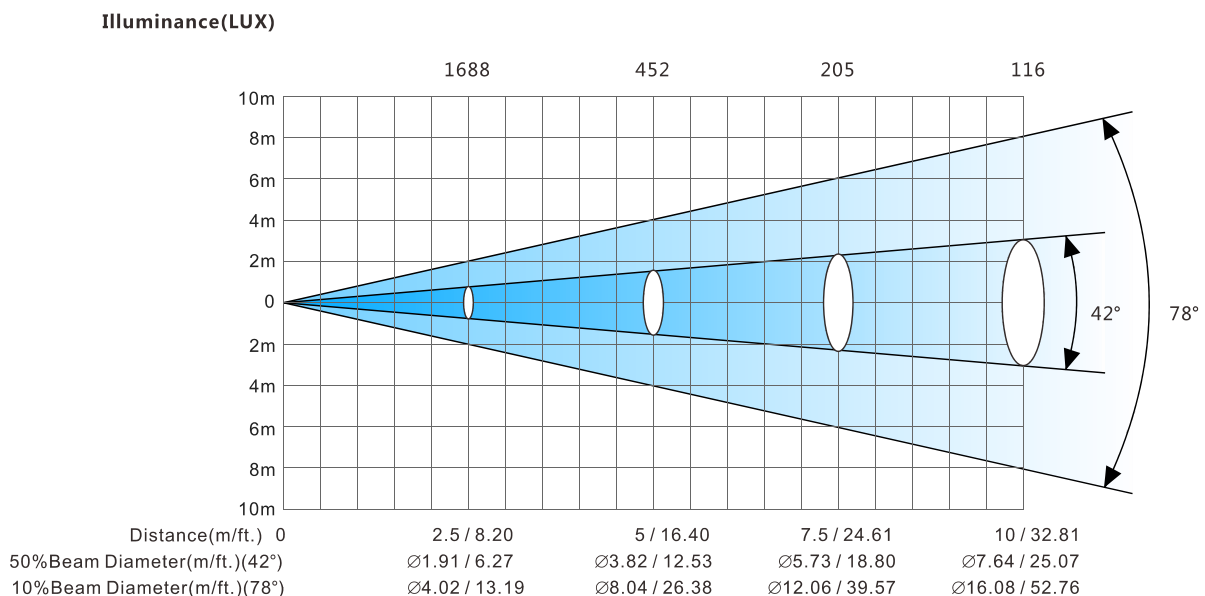

LYS011764 WW:

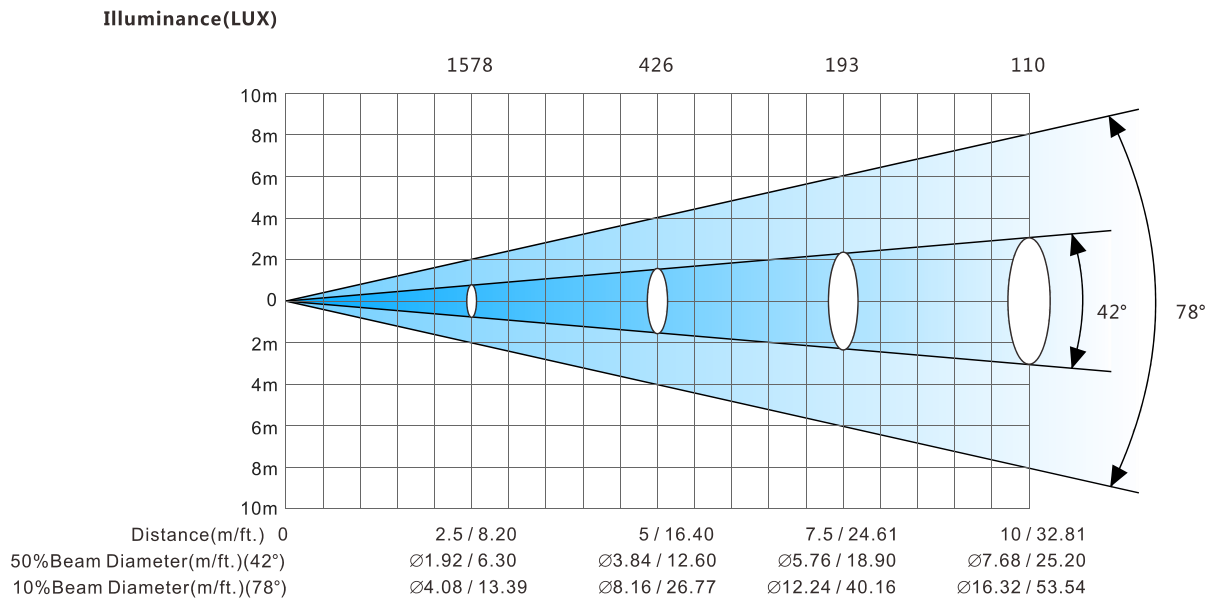

Cleaning and maintenance

It is required that the fixture should be kept clean and well maintained to ensure its reliability. Its lifespan mainly depends on the working environment and proper operation. Should you have any questions, please consult a technical engineer of GTD Lighting.

⚠Notes
 Damage resulted from dust, smoke, oil or improper use is not covered by warranty.

⚠Warning
 Disconnect the fixture from AC power, and let it cool down for at least 15 minutes before opening the housing. Make sure to use a soft cloth to clean the optical components, and be careful, as the coating is easily scratched. Do not use any organic solvent such as alcohol to clean the reflector mirror, dichroic color filters or housing of the fixture.

- If the lens is cracked or otherwise damaged, replace it immediately.
- If the LED lamp becomes damaged or deformed in any way it must be replaced.
- If the light from the LED lamp appears dim, this normally indicates that it is reaching the end of its life span and should be changed at once. Aged LED lamps run to the extremity of their life might explode.
- If fixture does not function, check the fuse on the power socket of the fixture. Replace the fuse of the same specification if it is blown.
- The fixture is equipped with thermal-protection device that will switch off the LED lamp in case of overheating. If this happens, please check that the fans are not blocked, and clean them if they are dirty. Check whether the fans are operational. If not, call a qualified technician. Troubleshoot and correct the problem before switching on the fixture again. Any maintenance work should only be carried out by qualified technicians.

Troubleshooting

Problem	Possible Cause	Suggested Correction
No response after connected to A/C power	Power switch not turned on.	Turn on power switch.
	Take out the fuse and check if it is blown.	Locate the blown fuse. Remove the broken fuse. Insert a replacement fuse of the correct amperage.
	Abnormal A/C input (A/C power socket, power cables, luminaire power socket).	Replace AC power socket and power cables, and then adjust power socket for proper connection.
	No DC voltage from switching power supply.	Check if the switching power supply has DC voltage output. Replace the switching power supply.
No response or wrong response to the commands of the control system	DMX cables disconnected from fixture's DATA IN connector.	Connect DMX cable to the fixture's DATA IN connector.
	Open circuit or short circuit fault in the DMX cables.	Replace DMX cables as required.
	Wrong DMX address for the fixture in the control system.	Ensure the address in "Run setting > Address Setting > Address" of the fixture is consistent with the address in the control system.
	Misuse in "Channel setting > Channel Mode" of the fixture.	Choose the channel mode in "Channel setting > Channel Mode" of the fixture as required by the user.
	Malfunctioning of DMX cannon input/output connectors. No input/output voltage to the main control board of the fixture.	Troubleshooting the DMX XLR signal plate of the fixture, replace the main control board of the fixture.
LED lamp off	There is no signal output to the main control board PWM.	Replace the main control board or repair.
	No output to the drive board LED +/- LED- or drive board over-current, check line connector if contact bad.	Reconnect the terminal, replace the driver board
	Normal end of LED lamp life, bad welding or poor heat dispersion.	Repair or replace LED light source or replace the whole piece of aluminum board, remove the cooling system failure.
Decreased brightness, uneven pattern projections	LED lamp aging, check the service time of LED light source, test LED drive board's current.	Replace the LED light source or adjust the drive board's current. Reduce LED's brightness.
	Excessive dusts or smudges on the effect assembly, focus module and objective lens.	Follow the instructions stated in this user manual to clean the effect assembly, focus module and objective lens.
	Damaged or deformed effect assembly, focus module or objective lens.	Replace the damaged or deformed components.

System wiring diagram

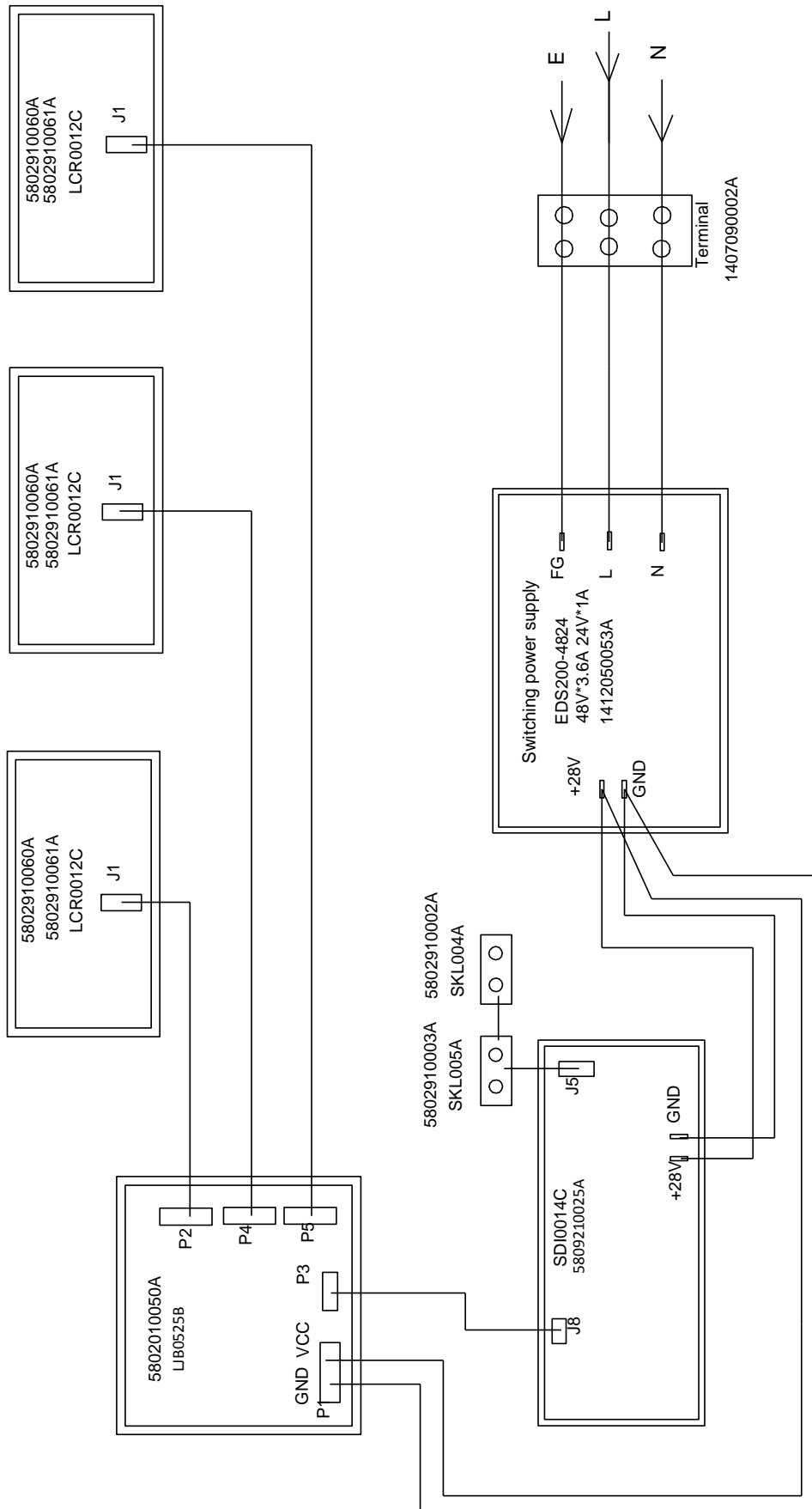

GTD-LYS011764

Spare parts list

Item	P/N	Qty	Notes
Display board	5809210025A	1	LYS01176-101E10& 102G10 SDI0014C
LED lamp board (WW)	5802910061A	3	LCR0012C
LED lamp board (CW)	5802910060A	3	LCR0012C
XLR board 4	5802910002A	1	SKL0004A
XLR board 5	5802910003A	1	SKL0005A
LED aluminum substrate	5802010050A	1	LJB0525B
Switching power supply	1412050053A	1	EDS200—4824 48V*3.6A 24V*1A

Appendix 1

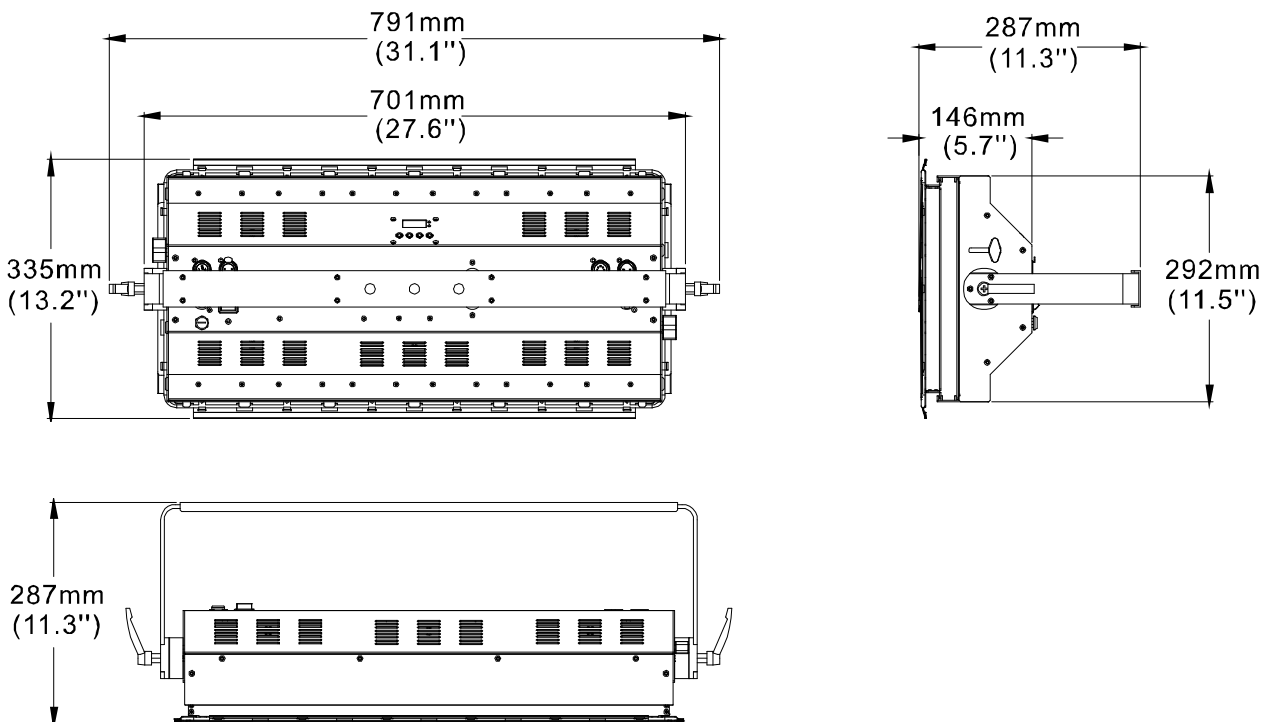

Notes:

P/N: 1502011040A
Time: August 9th, 2017